

**A conserved role for Asrij in regulating  
multiple signalling pathways during *Drosophila*  
and mouse hematopoiesis**

**A Thesis submitted for the degree of**

**Master of Science**

by

**Saloni Sinha**



**Molecular Biology and Genetics Unit**

**Jawaharlal Nehru Centre for Advanced Scientific Research**

**(A Deemed University)**

**Bangalore 560064**

**INDIA**

**April 2015**

*dedicated to my parents.....*

# Declaration

I hereby declare that this thesis entitled ‘**A conserved role for Asrij in regulating multiple signalling pathways during *Drosophila* and mouse hematopoiesis**’ is an authentic record of research work carried out by me under the guidance of Professor Maneesha S. Inamdar at Laboratory of Stem Cell Biology and Vascular Biology, Molecular Biology and Genetics Unit, Jawaharlal Nehru Centre for Advanced Scientific Research, Bangalore.

In keeping with the norm of reporting scientific observations, due acknowledgement has been made whenever work described here has been based on the findings of other investigators. Any omission owing to oversight or misjudgement is highly regretted.

Saloni Sinha

Bangalore

Date:

# Certificate

This is to certify that the work described here in this thesis entitled ‘**A conserved role for Asrij in regulating multiple signalling pathways during *Drosophila* and mouse hematopoiesis**’ is the result of investigations carried out by **Ms. Saloni Sinha** in Laboratory of Stem Cell Biology and Vascular Biology, Molecular Biology and Genetics Unit, Jawaharlal Nehru Centre for Advanced Scientific Research, Bangalore, India, under my guidance and that the results presented here have not previously formed the basis for the award of any other diploma, degree or fellowship.

Maneesha S. Inamdar

Bangalore

Date:

## Acknowledgements

*It is with immense gratitude that I acknowledge the guidance and support of my mentor, Professor Maneesha S. Inamdar. I would like to thank her for instilling in me the qualities of being a good researcher. Her infectious enthusiasm and unlimited zeal are the major driving forces that have helped me progress so far. I could not have imagined having a better advisor and mentor for my study.*

*I am thankful to my batchmates for their help and support. I thank Debanjan, Arpitha, Meenakshi, Somya and Alok from MBGU; Abhilash, Payel and Manan from EOBU for all the fun times we have had together.*

*Vascular Biology and Stem Cell Laboratory has always been a home away from home. I would like to thank my fellow lab members - Ronak, Deeti, Simi, Divyesh, Diana, Praveen, Arindam, Jasper, Kaustubh, Anudeep, Chetan and Shubhangini for all the help they have provided. I would like to specially thank Anudeep for helping me with my experiments. I am extremely thankful to Diana, for teaching me fly work; Jasper, for teaching me mouse handling and breeding techniques; Simi and Divyesh, for helping me with confocal imaging. I am extremely thankful to Ronak, Praveen, Deeti and Anudeep for helping me with flow cytometry analysis. I would also like to thank past members of the lab - Abhishek, Amogh, Ridim, Sudhir, Rohan and Priya. Our lab attendants, Nagaraj and Vijay have been always been of great help. I would like to thank Suma Ma'am of the JNCASR Confocal Facility and the JNCASR Central Instrumentation facility.*

*Having a good circle of friends is very important to survive the hardships of research. When my experiments did not work or when I was under a lot of pressure or when I missed home, I always had Abhilash, Kaustubh and Payel by my side, taking special care of me and cheering me up. I am extremely thankful to them for giving me the much needed emotional support.*

*Last, but not the least, a special thanks to my family members. Nothing would have been possible without their love and support. Words cannot express how grateful I am to my father and mother, for all the sacrifices that they have made for my happiness. Their blessings for me is what has sustained me so far. I thank my sister Sonal for loving me and caring for me like no one would do and cheering me up whenever I have felt low. I thank my grandmother (Nani) and grandfather (Daddy) for always remembering me in their prayers; my uncle, Dev and my aunt, Preeti, for everything they have done for me.*

# CONTENTS

	<b>Page No.</b>
<b>List of figures</b>	x
<b>List of tables</b>	xiii
<b>Abbreviations</b>	xiv
<b>Synopsis</b>	xvi
<b>Chapter 1: Introduction</b>	
1.1 <i>Hematopoiesis</i>	2
1.2 <i>Model systems to study hematopoiesis</i>	
1.2.1 <i>in vitro</i> model systems	4
1.2.2 <i>in vivo</i> model systems	
1.2.2.1 <i>Drosophila melanogaster</i> (fruit fly)	4
1.2.2.2 <i>Danio rerio</i> (zebrafish)	6
1.2.2.3 <i>Mus musculus</i> (mouse)	6
1.2.2.3.1 <i>Mammalian hematopoietic lineages</i>	7
1.3 <i>The hematopoietic stem cell niche</i>	8
1.4 <i>Signalling pathways involved in hematopoiesis of Mus musculus</i>	9
1.4.1 Wnt pathway	10
1.4.2 Hedgehog pathway	11
1.4.3 TGF- $\beta$ pathway	12
1.4.4 JAK/STAT pathway	13
1.4.5 PI3K/Akt pathway	14
1.4.6 Notch pathway	15
1.4.7 Ubiquitin Proteasome – COP9 signalosome pathway	18
1.5 <i>Hematological neoplasms – Disease perspective</i>	19
1.6 <i>Endosomes as signalling platforms</i>	21
1.7 <i>A key player in hematopoiesis – Asrij</i>	21
1.8 <i>Aims of the present study</i>	23
1.9 <i>Summary of the present study</i>	23

## Chapter 2: Using proteomics to build the Asrij network

2.1 <i>Introduction</i>	
2.1.1 Endosomal regulation of hematopoiesis	24
2.1.2 Understanding Asrij function using genetically modified <i>Drosophila</i> lymph glands	24
2.1.3 Advantages and challenges of proteomics using <i>Drosophila</i> lymph glands	25
2.2 <i>Materials and Methods</i>	
2.2.1 Fly stocks and genetics	26
2.2.2 Dissection and sample preparation for mass spectrometry	26
2.2.3 Protein lysate preparation from <i>Drosophila</i> lymph glands	26
2.2.4 <i>iTRAQ</i> labelling and LC with MS/MS	27
2.2.5 Analysis of mass spectrometry data	28
2.3 <i>Results</i>	
2.3.1 Gene ontology enrichment analyses highlights major molecular functions affected on perturbation of Asrij levels	29
2.3.2 Modulation of Asrij levels alters the protein landscapes of <i>Drosophila</i> lymph glands	33
2.4 <i>Discussion</i>	39

## Chapter 3: Functional role of Asrij in mouse hematopoiesis

3.1 <i>Introduction</i>	42
3.2 <i>Materials and Methods</i>	
3.2.1 Generation of Asrij knockout mice	43
3.2.2 Validation of Asrij knockout mice	44
3.2.3 Western Blotting	45
3.2.4 Antibodies used for Western Blotting	45
3.2.5 Immunostaining of bone marrow cells	45

3.2.6 Antibodies used for immunostaining	46
3.2.7 Complete blood cell counts	46
3.2.8 Flow cytometry analysis of bone marrow compartment	46
3.2.9 Imaging and analysis	47
3.2.10 Statistical analysis and quantification	47
3.3 <i>Results</i>	
3.3.1 Asrij knockout mice are viable	47
3.3.2 Expression analysis of Asrij in mouse bone marrow cells	48
3.3.3 Steady state hematopoiesis is affected in Asrij knockout mice	49
3.3.4 Increase in the HSC population in Asrij knockout mice	51
3.4 <i>Discussion</i>	52
<b>Chapter 4: Role of Asrij in regulating signalling pathways that maintain mouse hematopoiesis</b>	
4.1 <i>Introduction</i>	55
4.2 <i>Materials and Methods</i>	
4.2.1 Immunostaining of bone marrow cells	56
4.2.2 Western Blotting analysis	56
4.2.3 Imaging and analysis	57
4.2.4 Statistical analysis and quantification	57
4.3 <i>Results</i>	
4.3.1 Asrij regulates STAT3 activation in mice	58
4.3.2 Increased activation of the PI3K/Akt pathway in mice	59
4.3.3 Asrij negatively regulates Notch pathway in mice	60
4.3.4 Asrij regulates expression of COP9 signalosome components	62
4.3.5 Increased ubiquitin levels in Asrij knockout mice	64
4.4 <i>Discussion</i>	
4.4.1 Asrij positively regulates the JAK/STAT pathway	66



4.4.2 Asrij negatively regulates the PI3K/Akt pathway	66
4.4.3 Asrij modulates Notch trafficking	67
4.4.4 Asrij affects expression of COP9 signalosome components	68
4.4.5 Asrij depletion leads to increased ubiquitin levels	69
4.5 <i>Concluding Remarks</i>	70
<b>Chapter 5: Phenotypic analysis of <i>asrij<sup>fl/fl</sup>;Cre</i> mice tissues</b>	
5.1 <i>Introduction</i>	72
5.2 <i>Materials and Methods</i>	
5.2.1 Radiography of mice	73
5.2.2 Alcian Blue and Alizarin Red staining	73
5.2.3 Bone marrow processing for cryosectioning	74
5.2.4 Cryosectioning	74
5.2.5 Paraffin sectioning	75
5.2.6 Hematoxylin and eosin (H&E) staining	75
5.2.7 Microscopy and Imaging	76
5.3 <i>Results</i>	
5.3.1 Soft X-ray analysis reveals kyphosis in <i>asrij<sup>fl/fl</sup>;Cre</i> mice	76
5.3.2 Loss in cellularity of bone marrow upon Asrij deletion	79
5.3.3 Splenomegaly in <i>asrij<sup>fl/fl</sup>;Cre</i> mice	80
5.4 <i>Discussion</i>	82
<b>Chapter 6: Discussion</b>	
6.1 Asrij is a conserved endocytic protein	85
6.2 Asrij modulates several signalling pathways by virtue of its endocytic location	85
6.3 Asrij is a key regulator of hematopoiesis	92
6.4 <i>asrij<sup>fl/fl</sup>;Cre</i> mice as leukemic models	93

## List of figures

	Page No.
<b>Chapter 1: Introduction</b>	
1.1 Schematic representing an overview of HSCs and LSCs	3
1.2 Lymph gland, hematopoietic tissue of <i>Drosophila melanogaster</i>	5
1.3 Shifting sites of hematopoiesis across different developmental stages in <i>Mus musculus</i>	7
1.4 Bone marrow hematopoiesis	8
1.5 Niches of the bone marrow	9
1.6 Schematic representing Wnt signalling pathway	10
1.7 Schematic representing Hedgehog signalling pathway	11
1.8 Schematic representing TGF- $\beta$ signalling pathway	12
1.9 Schematic representing JAK/STAT signalling pathway	14
1.10 Schematic representing the PI3K/Akt pathway	15
1.11 Schematic representing Notch signalling pathway	16
1.12 Role of Notch signalling in embryonic and adult hematopoiesis	17
1.13 Schematic representing different types of hematological neoplasms	20
<b>Chapter 2: Using proteomics to build the Asrij network</b>	
2.1 <i>iTRAQ</i> -based quantitative proteomics of <i>Drosophila melanogaster</i> lymph glands	27
2.2 Gene ontology analysis of the lymph gland proteome of <i>Drosophila melanogaster</i>	30
2.3 Venn diagram showing overlap of differentially expressed proteins under Asrij knockout and overexpression conditions	34
2.4 Differentially expressed proteins of the cellular transport machinery upon Asrij perturbation	35
2.5 Differentially expressed proteins of the JAK/STAT pathway upon Asrij perturbation	36
2.6 Differentially expressed proteins of the oxidative phosphorylation machinery upon Asrij perturbation	39

### **Chapter 3: Functional role of Asrij in mouse hematopoiesis**

3.1 Schematic representing asrij exon 6 gene targeting	44
3.2 Genotyping by PCR	45
3.3 Western Blotting of mouse tissue lysates for confirmation of genotype	48
3.4 Asrij is expressed in the hematopoietic cells of the bone marrow	48
3.5 Increased blood cell counts in <i>asrij<sup>fl/fl</sup>;Cre</i> mice	50
3.6 Flow cytometry analysis revealed an increase in the HSC population in <i>asrij<sup>fl/fl</sup>;Cre</i> mice	51
3.7 Asrij negatively regulates proliferation and differentiation of bone marrow HSCs	53

### **Chapter 4: Role of Asrij in regulating signalling pathways that maintain mouse hematopoiesis**

4.1 Asrij positively regulates the JAK/STAT pathway in mice	58
4.2 Over-activation of the PI3K/Akt pathway in Asrij deficient mice	60
4.3 Notch pathway is over-activated in <i>asrij<sup>fl/fl</sup>;Cre</i> mice bone marrow	61
4.4 Increased NICD levels in <i>asrij<sup>fl/fl</sup>;Cre</i> mice tissues	62
4.5 Expression of COP9 signalosome components is affected in <i>asrij<sup>fl/fl</sup>;Cre</i> mice	63
4.6 Increased ubiquitin levels in Asrij deficient mice bone marrow cells	64
4.7 Increased ubiquitin levels in <i>asrij<sup>fl/fl</sup>;Cre</i> mice tissues	65

### **Chapter 5: Phenotypic analysis of *asrij<sup>fl/fl</sup>;Cre* mice**

5.1 Necropsy of 1 year old <i>asrij<sup>fl/fl</sup>;Cre</i> mice	76
5.2 Development of skeletal defects in adult <i>asrij<sup>fl/fl</sup>;Cre</i> mice	77
5.3 Alcian Blue and Alizarin Red staining of <i>asrij<sup>fl/fl</sup></i> and <i>asrij<sup>fl/fl</sup>;Cre</i> mice	78
5.4 Evaluation of <i>asrij<sup>fl/fl</sup>;Cre</i> mice bone marrow architecture	80
5.5 Deletion of Asrij results in splenomegaly	81
5.6 Histological analysis of spleen isolated from <i>asrij<sup>fl/fl</sup></i> and <i>asrij<sup>fl/fl</sup>;Cre</i> mice	82

## **Chapter 6: Discussion**

6.1 Model - Asrij negatively regulates the Notch pathway	87
6.2 Model - Asrij regulates the expression levels of the COP9 signalosome	89
6.3 Model - Asrij negatively regulates the PI3K/Akt pathway	90
6.4 Model - Asrij regulates signals originating from several pathways	91
6.5 Hematopoietic and signalling defects in Asrij knockout mice	94

## List of tables

	Page No.
<b>Chapter 2: Using proteomics to build the Asrij network</b>	
2.1 Proteins of the ESCRT complex affected upon perturbation of Asrij levels	35
2.2 List of proteins involved in the JAK/STAT pathway that are differentially expressed upon Asrij perturbed conditions	37
2.3 List of proteins involved in the Notch pathway that are differentially expressed upon Asrij perturbed conditions	38
<b>Chapter 3: Role of Asrij in regulating signalling pathways that maintain mouse hematopoiesis</b>	
3.1 Peripheral blood hemogram of 6 months old <i>asrij<sup>fl/fl</sup></i> and <i>asrij<sup>fl/fl</sup>;Cre</i> mice	50
<b>Chapter 4: Role of Asrij in regulating signalling pathways that maintain mouse hematopoiesis</b>	
4.1 List of primary antibodies and their dilutions used for various Western blottings	57

## Abbreviations

ANOVA	Analysis of Variance
bp	base pairs
COP9	Constitutively Photomorphogenic 9
CSN	Constitutively Photomorphogenic signalosome
C	Control
Da	Dalton
DAPI	4', 6-Diamidino-2-Phenylindole, dihydrochloride
ESC	Embryonic stem cell
ESCRT	Endosomal Sorting Complex for Transport
g	gram
X g	times gravity
GAPDH	Glyceraldehyde 3-phosphate dehydrogenase
Hh	Hedgehog
HPC	Hematopoietic progenitor cell
HSC	Hematopoietic stem cell
Hrs	Hepatocyte growth factor regulated tyrosine kinase substrate
JAK	Janus associated kinase
kg	kilogram
KO	Knockout
mESC	Mouse embryonic stem cell
mm	millimetre
NF-E2	Nuclear factor, erythroid 2
NICD	Notch Intracellular domain
No.	Number
OCIAD1	Ovarian Carcinoma Immunoreactive Antigen
PBS	Phosphate Buffer Saline
PDGF	Platelet derived growth factor
PF	Paraformaldehyde
PI cocktail	Protease Inhibitor Cocktail
PI3K	Phosphoinositide 3 kinase
ppm	part per million

Pvr	PDGF-VEGF receptor
rpm	revolution per minute
RPTK	Receptor Protein Tyrosine Kinase
SDS	Sodium Dodecyl Sulphate
STAT	Signal Transducer and Activator of Transcription
TGF- $\beta$	Transforming growth factor- $\beta$
VEGF	Vascular endothelial growth factor
Vps	Vacuolar Protein Sorting
$\mu\text{g}/\mu\text{l}$	microgram/microliter

Synopsis of the thesis entitled

**A conserved role for Asrij in regulating multiple signalling pathways during *Drosophila* and mouse hematopoiesis**

*Submitted by*

**Saloni Sinha**

Molecular Biology and Genetics Unit,

Jawaharlal Nehru Centre for Advanced Scientific Research,

Jakkur, Bangalore – 560064, India.

Thesis advisor: Professor Maneesha S. Inamdar

**This thesis describes the functional analysis of the endocytic protein Asrij in mouse hematopoietic development. Recently, endosomal trafficking has been shown to actively regulate stem cell differentiation. By virtue of their cellular location, endosomal proteins are well-positioned to act as ‘signalling platforms’ and are thus potential regulators of various cellular processes including hematopoiesis. Several signalling pathways control hematopoiesis but there is limited understanding of the complex mechanisms that govern it. My study focuses on an OCIA-domain containing endocytic protein, Asrij, which functions to maintain the balance between stemness and differentiation. Asrij interacts with ARF1, a known endosomal protein and actively regulates JAK/STAT, Notch and PDGF-VEGF signalling pathways in *Drosophila* for maintenance of blood cell homeostasis. Based on our proteome analysis, I have identified novel components of the Asrij network in *Drosophila melanogaster*, whose disruption leads to hematological malignancies. Owing to the high conservation of signalling pathways and molecules across evolution, we extended our analysis to the vertebrate model. *asrij<sup>fl/fl</sup>;Cre* mice are viable and fertile but peripheral blood count analyses reveal increased WBC and platelet counts, indicating that steady state hematopoiesis is perturbed. Deficiency of Asrij in mouse induces phenotypes such as skeletal defects, splenomegaly and causes increment in the long-term hematopoietic stem cells (LT-HSCs). Besides, immunoblotting analyses of *asrij<sup>fl/fl</sup>;Cre* mouse tissues reveal increased levels of ubiquitin, NICD, phospho-Akt and COPS5. Taken together, my data confirms *asrij<sup>fl/fl</sup>;Cre* mice as an excellent model to study hematological neoplasms. This study offers novel insight into conserved mechanisms of hematopoiesis and will be applicable to understanding stem cell regulation.**

Establishment and maintenance of the blood system, which is termed as hematopoiesis, relies on an intricate network of cellular interactions. Detailed understanding of this process will not only help provide critical insights into the mechanisms that underlie hematopoiesis but also aid in employment of therapeutic targets to treat various hematological neoplasms. Several model systems such as the fruit fly, *Drosophila melanogaster* and the house mouse, *Mus musculus* have been studied for characterization of the fine-tuned and complex regulatory networks that comprise hematopoiesis. These model systems are widely used and are relevant for studying the conserved mechanisms of



hematopoiesis. Besides, several parallels exist between *Drosophila* and vertebrate hematopoiesis and both have different spatial and temporal phases.

In *Drosophila*, an initial wave of hematopoiesis occurs in the procephalic mesoderm that then shifts to the primary lobes of the larval lymph gland. The lymph gland consists of three different zones; the Posterior Signalling Centre (PSC) that houses the stem cell niche, the Medullary Zone (MZ) that contains the prohemocytes and the Cortical Zone (CZ) that is made up of differentiated hemocytes. Likewise, vertebrates too have shifting sites of hematopoiesis across different developmental stages, which occur in two successive waves viz., primitive and definitive. Primitive hematopoiesis occurs in the extra-embryonic yolk sac blood islands predominantly geared towards erythropoiesis. The definitive wave of hematopoiesis occurs in parallel in several tissues such as the aorta-gonad mesonephros (AGM), placenta and fetal liver, generating blood cells of all lineages. In adult vertebrates, the major sites of hematopoiesis are the spleen and bone marrow.

Co-ordination and integration of various inputs from signalling pathways such as Notch, JAK/STAT and PI3K/Akt maintain and regulate bone marrow hematopoiesis. Disrupting the function of any molecule playing a vital role in this process affects blood cell homeostasis and leads to leukemic transformation. Recently, a series of studies have highlighted that active regulation of cell signalling is not restricted to the plasma membrane or soluble cytosolic factors but also extends to endosomes. Endosomes constitute the intracellular signalling machinery that mediates cross-talk among signalling components. They provide an ideal physical platform for propagation of intracellular signalling circuitries aiding in the execution of a vast number of biological programs. Perturbation of the endosomes or endosomal routes is likely to take a toll on various signalling pathways, thereby affecting an array of cellular functions. I therefore chose to study the role of the blood-specific endosomal protein Asrij in *Mus musculus*, for elucidating the molecular wiring underlying hematopoiesis.

Asrij, a pan-hemocyte marker, is a key player of hematopoiesis in *Drosophila melanogaster*. Asrij null flies display aberrant hematopoietic phenotypes such as enlargement of primary and secondary lobes of the lymph gland and increased proliferation and differentiation of hemocytes. The endosomal protein Asrij has a conserved role in maintaining the balance between stemness and differentiation, mediated by its OCIA (Ovarian Carcinoma Immunoreactive Antigen) domain. Asrij facilitates the endosomal activation of STAT3 and also regulates Notch signalling to maintain blood cell homeostasis in *Drosophila*. Besides, the Asrij-ARF1 (ADP Ribosylation factor-1) axis is integral to endosomal regulation of multiple signalling pathways in hematopoiesis. Previous studies have shown that Asrij biochemically interacts with STAT3 and aids in its phosphorylation, which is important for maintenance of stemness in mouse ES cells. Interestingly, mouse Asrij and *Drosophila* Asrij are homologs and mouse Asrij can maintain the stem cell state in *Drosophila*.

The role of Asrij in endocytosis is largely unknown. Asrij functions at multiple levels during hematopoiesis and this makes it difficult to tease apart its exact mechanism of action. To fetch answers to the question as to how an endosomal protein Asrij can fine tune the delicate balance between stemness and differentiation, we opted for a quantitative proteomics based approach in *Drosophila melanogaster*, a simpler and genetically tractable model. Using

genetically modified *Drosophila* lymph glands, an iTRAQ based quantitative proteomics analysis was performed in *Asrij* depleted and overexpressed conditions. Of 870 proteins whose expression was dependent on *Asrij* levels, 58 were reciprocally regulated in *Asrij* depleted and overexpression lymph glands. The major cellular processes and pathways affected were endocytosis, oxidative phosphorylation and metabolism. Expectedly, components of the JAK-STAT and Notch signalling pathways and a wide array of molecules involved in the endocytic pathway showed altered expression. Proteomics of the genetically modified lymph glands could not only help interrogate changes at the protein level but also help in finding several potential regulators of hematopoiesis whose activity might be *Asrij* dependent. Finding these potentially novel regulators could help unravel protein networks and circuitry that control hematopoiesis.

Given the high conservation of molecules and signalling pathways across taxa, I extended my analysis to the vertebrate model. *asrij<sup>fl/fl</sup>;Cre* mice generated previously by the targeted mutation of exon 6 via Cre-LoxP recombination that completely lacked *Asrij* protein were used for all the analyses. *asrij<sup>fl/fl</sup>;Cre* mice were viable and fertile but complete peripheral blood counts of different age groups of *asrij<sup>fl/fl</sup>;Cre* mice revealed significantly increased population of WBCs and platelets, implying perturbation of steady state hematopoiesis. Often, defects in steady state hematopoiesis imply functional impairment of hematopoietic stem cells and progenitor cells in the bone marrow compartment. In addition, *asrij<sup>fl/fl</sup>;Cre* mice had severely disrupted bone marrow homeostasis as was reflected by marked increase in the LT-HSCs. To conclude, loss of *Asrij* affected steady state hematopoiesis and led to aberrant hematopoiesis in the bone marrow.

Perturbation of *Asrij*, an endocytic protein, that functions to maintain the balance between stemness and differentiation, is likely to impinge upon several signalling pathways that regulate hematopoiesis. Previous studies have shown that increased entrapment of NICD in sorting endosomes in *Asrij* null flies leads to enhanced crystal cell differentiation. Up-regulation or forced expression of cleaved Notch 1 in mice leads to expansion of HSCs. Increased NICD levels across different age groups of *asrij<sup>fl/fl</sup>;Cre* mice imply that *Asrij* regulates Notch signalling in vertebrates too. Immunoblotting analyses across different age-groups of *asrij<sup>fl/fl</sup>;Cre* mice tissues (heart, kidney, liver and spleen) revealed a dramatic increase in the levels of ubiquitination. In addition, loss of *Asrij* caused increased levels of COPS5/CSN5. COPS5 is a component of the COP9 signalosome, a protein assembly that functions at the interface of signal transduction and ubiquitin-dependent proteolysis. Deregulation of the ubiquitin-proteasome machinery eventually disturbs homeostasis and leads to the development of tumor-initiating cells. We also analysed the effect of *Asrij* knockout on the JAK/STAT pathway. Biochemical analysis revealed that pSTAT3 levels were reduced in *asrij<sup>fl/fl</sup>;Cre* mice tissues, the consequences of which are yet to be determined. PI3K/Akt signalling plays an important role in cell growth and survival. Constitutive activation of Akt (phosphorylation at Serine 473) in mice leads to premature exhaustion of hematopoietic stem cells and results in myeloproliferative disorder (MDS). *Asrij* deficiency brought about an increase in phospho-Akt levels indicating that *asrij<sup>fl/fl</sup>;Cre* mice could be associated with MDS.

Taken together, *Asrij* affects the Notch signalling pathway, ubiquitin proteasome degradation pathway, PI3K/Akt pathway, JAK/STAT pathway and components of the COP9 signalosome. *Asrij* has a conserved role as it regulates similar signalling networks in

vertebrates. Loss of *Asrij* leads to increased pathway activation and various lines of evidence presented so far suggest *asrij<sup>fl/fl</sup>;Cre* mice to be associated with hematological neoplasms.

Further, *asrij<sup>fl/fl</sup>;Cre* mice displayed a number of abnormalities such as splenomegaly and skeletal defects. Splenomegaly in *asrij<sup>fl/fl</sup>;Cre* mice was indicative of an underlying hematopoietic disorder. With increasing age, *asrij<sup>fl/fl</sup>;Cre* mice exhibited severe thoracic kyphosis; radiography and skeletal staining studies of *asrij<sup>fl/fl</sup>;Cre* mice showed the presence of a persistent hump. Phenotypic analyses of the bone marrow compartment of *asrij<sup>fl/fl</sup>;Cre* mice showed a major loss of cellularity. Apart from this, a common observation was muscle atrophy in *asrij<sup>fl/fl</sup>;Cre* mice, a condition termed as cachexia, which involves wastage of adipose tissue and skeletal muscle.

**In summary, the endocytic molecule *Asrij* has a conserved role in mediating control of signalling networks for regulation of hematopoiesis in vertebrates. Disruption of *Asrij*-governed endocytic circuitries can therefore result in hematological neoplasms. This study establishes a previously unrecognized role for *Asrij* in bone marrow hematopoiesis and that its deficiency results in hematological neoplasms.**

## **Chapter 1: Introduction**

Studies of hematopoiesis serve as a paradigm for understanding stem cell properties. Stem cells, by definition, are unspecialized cells with the remarkable potential to self-renew as well as give rise to differentiated and mature cell types in an organism. As stem cells mature, they undergo changes in their gene expression patterns for progressive specification towards a particular cell type. Based on their origin, stem cells are of two kinds, viz., ‘embryonic’ and ‘non-embryonic’ which includes fetal and adult stem cells. Embryonic stem cells, derived from the undifferentiated inner cell mass of the blastocyst, can potentially contribute to descendants of all the three germ layers (ectoderm, mesoderm and endoderm), whereas fetal and adult stem cells are mostly found among differentiated cells of various tissues with limited differentiation potential (Nichols and Smith, 2011; Snippert and Clevers, 2011). Regardless of their source, stem cells have the unique properties of self-renewability and potency to give rise to any specialized cell types. Thus, stem cells are promising candidates for regenerative therapies and have potential applications for treatment of blood diseases, neurodegenerative disorders and diabetes (Koerbling and Estrov, 2003; Scadden and Srivastava, 2012).

Understanding how stem cells can be harnessed for regenerative therapies is an active area of research. The nature of niches that regulate self-renewal and differentiation of stem cells is not well understood. Regulation of stem cells by the niche is enforced by an array of extrinsic and intrinsic cellular factors that function in coordination. Loss of activity of any of these key factors leads to disruption of the signalling circuitries governing stem cell maintenance (Tam and Lim, 2008; Fong et.al., 2012).

Endosomes provide opportunity for cross-talk among various signalling pathways as they dynamically interact with signal receptors and effectors and hence can be considered

master regulators of cell signalling (Sigismund et. al., 2012). Endosomes are ideally positioned to modulate various inputs received by the cell and also provide spatial and temporal control of cell signalling and transport processes (Benmerah, 2004; Zastrow and Sorkin, 2007). Hence, we choose to interrogate changes occurring at the endocytic level that enable control of stem cell fate and cell reprogramming. Our research focuses on hematopoietic stem cells (HSCs) as it is a compelling model for analysis of mechanisms governing stemness. Previous studies (Bank, 2003; Felfly and Haddad, 2014) have increased our understanding of HSCs and their application for therapeutic purposes. Though, HSC transplantation (HSCT) has rapidly evolved as a reliable cure for several types of blood cancers, there are major roadblocks to the use of HSCs for clinical applications such as hematopoietic engraftment failure and problems of graft-versus-host disease (GVHD) (Shizuru et. al., 1996). Various strategies such as increased immunosuppression of the host and chemotherapy have been tried to make HSCTs successful, yet all efforts have met with limited success. The key to successful HSCTs lies in the elucidation of the elements required for establishing functional long-term hematopoiesis; as this would not only ensure homing and expansion of HSCs but also reduce the risk of rejection (Quinones et. al., 1993; Locatelli et. al., 2014). Therefore, studying HSCs will help in gaining a better understanding of the mechanisms underlying normal as well as malignant hematopoiesis.

### **1.1 Hematopoiesis**

Generation of blood cells of various lineages in a hierarchical and stepwise manner from immature hematopoietic stem cells (HSCs) is termed as hematopoiesis. HSCs sit atop a hierarchy of progenitors and are defined by their ability to contribute to an organised set of progenitors for constitution of the entire blood system of an organism (Warr and Passague, 2011). HSCs serially replenish the blood system in cases of immune challenge, radiation or chemotherapy and are also known to conduct immune-surveillance checks. Quiescence has been proposed to be a fundamental property of HSCs, which ensures life-long tissue

maintenance and helps protect the stem cell pool from premature exhaustion. HSCs localize to specific microenvironments in the tissues, called the stem cell niches, where they are preferentially maintained by various intrinsic and extrinsic cellular factors (Chotinantakul et. al., 2012). Disruption of the balance between blood cell turnover and their replenishment by HSCs result in a heterogeneous group of disorders, collectively termed as hematological neoplasms. These are usually initiated by a pool of leukemic stem cells (LSCs) that display the ability to self-renew and differentiate, albeit in an aberrant fashion, culminating in cancer (Warr and Passegue, 2011) (Refer Figure 1.1).

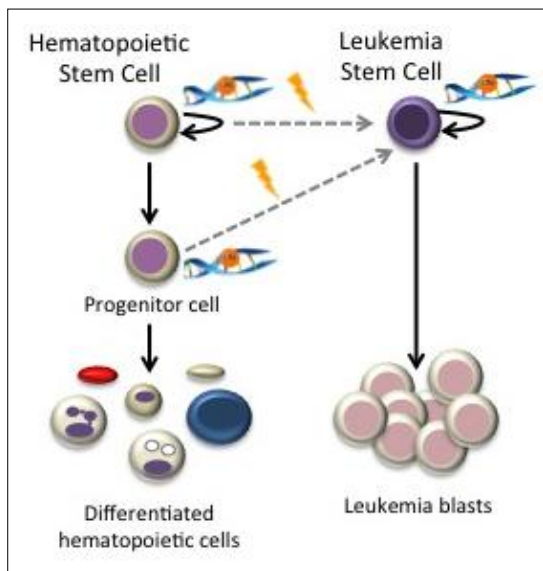

**Figure 1.1: Schematic representing an overview of HSCs and LSCs.** Normally, HSCs function to give rise to differentiated cells of the lymphoid and myeloid lineages. Various complex genetic mutations in the HSCs or HPCs give rise to LSCs. Unravelling the precise molecular machinery underlying HSCs and LSCs will help in generation of more effective therapeutic strategies (Modified from <https://trowbridgelab.files.wordpress.com/2012/09/slide1-copy.jpg>).

The first tissue-specific stem cells to be isolated were the HSCs (Spangrude et. al., 1998). HSCs aid in the treatment of a variety of leukemias and autoimmune disorders and are routinely used for blood and bone marrow transplantations (Weismann, 2000). Genetic programs of hematopoiesis are mostly conserved across various taxa (Evans et. al., 2003). Various *in vitro* and *in vivo* models are used for understanding hematopoiesis (Ploemacher et. al., 1997; Domen and Weismann, 1999).

## **1.2 Model systems to study hematopoiesis**

### **1.2.1 *in vitro* model systems**

Various *in vitro* model systems have been used for studying hematopoiesis such as mouse embryonic stem cells (mESCs), avian cell cultures, leukemia-lymphoma cell cultures, etc. mESCs are pluripotent and can be cultured with relative ease in the laboratory. Differentiating mESCs provide an excellent model for understanding the processes governing induction and differentiation of stem cells to their committed progenitors (Snodgrass et. al., 1992). Avian cell cultures are a unique model system for studying normal as well as abnormal hematopoiesis owing to their long life span, almost 30 to 50 generations (Beug et. al., 1995). Researchers have also tried using malignant cell lines such as leukemia-lymphoma cell lines as these are invaluable for studying various hematological neoplasms (Drexler and Matsuo, 2000).

*In vitro* model systems have a common disadvantage; all of them lack cellular diversity which can be provided only by the complex microenvironment of the niche and its stem cells. Recently, bone marrow fabricated chips have been engineered which help in retaining the HSCs and HPCs in their normal *in vivo*-like environment. This biomimetic microdevice offers an excellent model system for studying processes underlying normal as well as malignant hematopoiesis (Torisawa et. al., 2014).

### **1.2.2. *in vivo* model systems**

Various *in vivo* model systems such as *Drosophila melanogaster*, *Danio rerio* and *Mus musculus* have been widely used for studying hematopoiesis.

#### **1.2.2.1 *Drosophila melanogaster* (fruit fly) as a model system to study hematopoiesis**

*Drosophila* is a widely used model for analysis of stemness owing to its limited gene redundancy as compared to vertebrates, short life cycle and easy rearing conditions. Analysis of

gene function is relatively simple in *Drosophila* making it an excellent model for elucidating the molecular underpinnings of hematopoiesis (Neckameyer, 2013). Given the high conservation of molecules and signalling pathways across taxa, studies on *Drosophila* can be extended to vertebrates. Besides, several significant parallels exist between *Drosophila* and vertebrate hematopoiesis and both have different spatial and temporal phases (Makhijani et. al., 2011).

In *Drosophila*, an initial wave of hematopoiesis occurs in the procephalic mesoderm, which primarily gives rise to plasmatocytes and crystal cells. The site of hematopoiesis then shifts to the primary lobes of the larval lymph gland. The lymph gland consists of three different zones; the Posterior Signalling Centre (PSC) that houses the stem cell niche, the Medullary Zone (MZ) that contains the prohemocytes and the Cortical Zone (CZ) that is made up of the differentiated hemocytes (Refer Figure 1.2). This specialized larval tissue contains hematopoietic progenitors for the production of all three types of blood cells, namely, plasmatocytes, crystal cells and lamellocytes. Plasmatocytes are involved in phagocytosis of foreign bodies, crystal cells are required for melanisation, whereas lamellocytes are devoted to the encapsulation of foreign bodies too large to be engulfed by the plasmatocytes (Crozatier and Vincent, 2011).

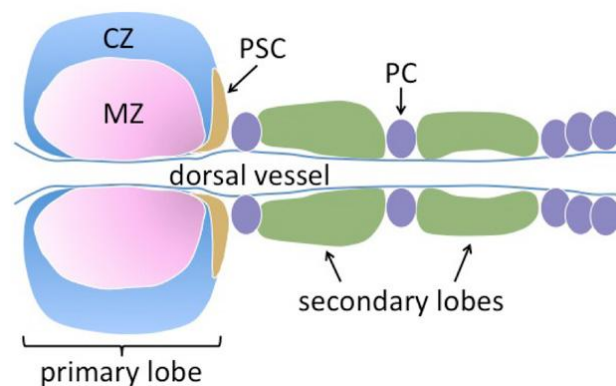

**Figure 1.2: Lymph gland, the specialised hematopoietic tissue of *Drosophila melanogaster*.** Lymph gland is the site of intensive investigation for understanding mechanisms underlying hematopoiesis. It is a multi-lobed tissue that lies across the dorsal vessel bearing primary lobes and secondary lobes separated by pericardial cells



(PC). The primary lobes of the lymph gland are well-characterized and have three distinct zones: the Posterior Signalling Centre (PSC), Medullary Zone (MZ) and the Cortical Zone (CZ) which house the stem cell niche, prohemocytes and differentiated hemocytes, respectively (*Modified from Jung et. al., 2005*).

#### **1.2.2.2 Zebra fish (*Danio rerio*) as a model system to study hematopoiesis**

Genetic programs of hematopoiesis are conserved in zebrafish too, making it a good model for studying hematopoiesis (Zon et. al., 2008). Zebrafish have sequential waves of hematopoiesis (Davidson and Zon, 2004) but hematopoiesis occurs in distinct sites such as the kidney marrow, which is the functional equivalent of bone marrow in mammals. Further, its transparent embryos provide ease of manipulation and the ability to perform desired genetic and chemical screens (Lieschke and Currie, 2007).

#### **1.2.2.3 Mouse (*Mus musculus*) as a model system to study mammalian hematopoiesis**

With the advancement in transgenic technology, the mouse has become an excellent model to study the processes involved in development. Analyses of several transgenic mouse models harboring mutations have greatly enhanced our understanding about the mechanisms of intricate signalling processes governing hematopoiesis. The availability of specific gene manipulation tools like promoter Cre-drivers for specific tissues make mice amenable to detailed molecular-genetic analyses. Given that hematopoiesis is a conserved process, presumably, especially in mammals, analysing mouse models have complemented and extended studies of human hematopoiesis.

The major sites of hematopoiesis in vertebrates keep shifting from one to the other across different developmental stages. Based on the spatial and temporal phases, hematopoiesis in the vertebrate embryo can be classified as primitive and definitive. The first wave of hematopoiesis in the mouse embryo that takes place in the extra-embryonic yolk sac, as early as embryonic day (E) 7.5, is termed as the primitive wave of hematopoiesis, which is geared

towards erythropoiesis, i.e., the production of red blood cells. On the other hand, the definitive wave of hematopoiesis, occurs in parallel in several other tissues such as the aorta-gonad mesonephros (AGM) and placenta by E8.5 and E10, respectively, for the generation of blood cells of all lineages. Later in vertebrate embryogenesis, HSCs seed the fetal liver. Around E17.5 in the mouse, the HSCs leave the fetal liver and colonize the bones making it the major site of hematopoiesis in the adult vertebrates, apart from the thymus and spleen (Pietras and Passegue, 2011) (Refer Figure 1.3).

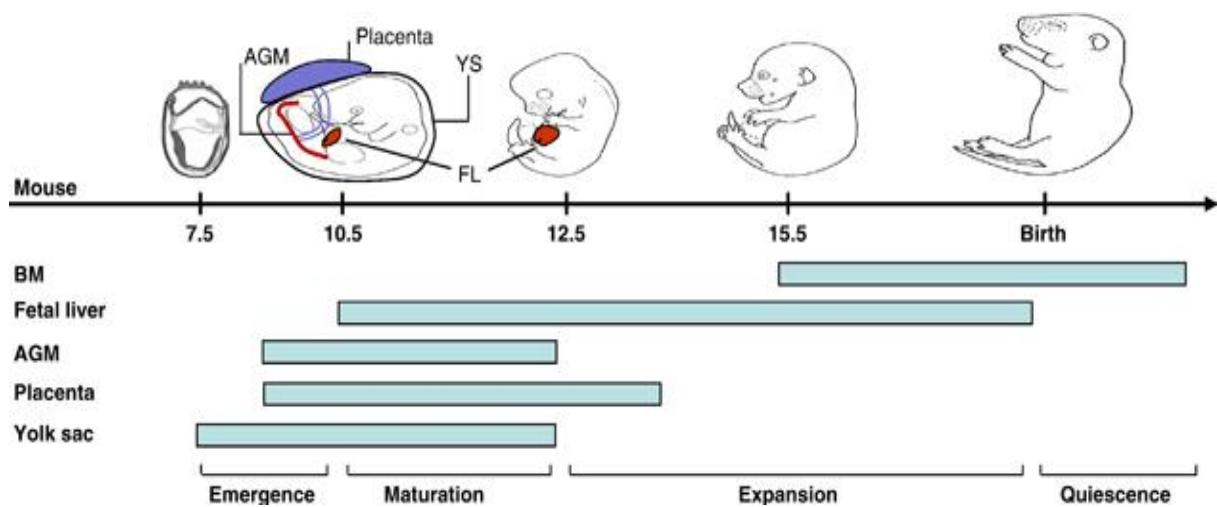
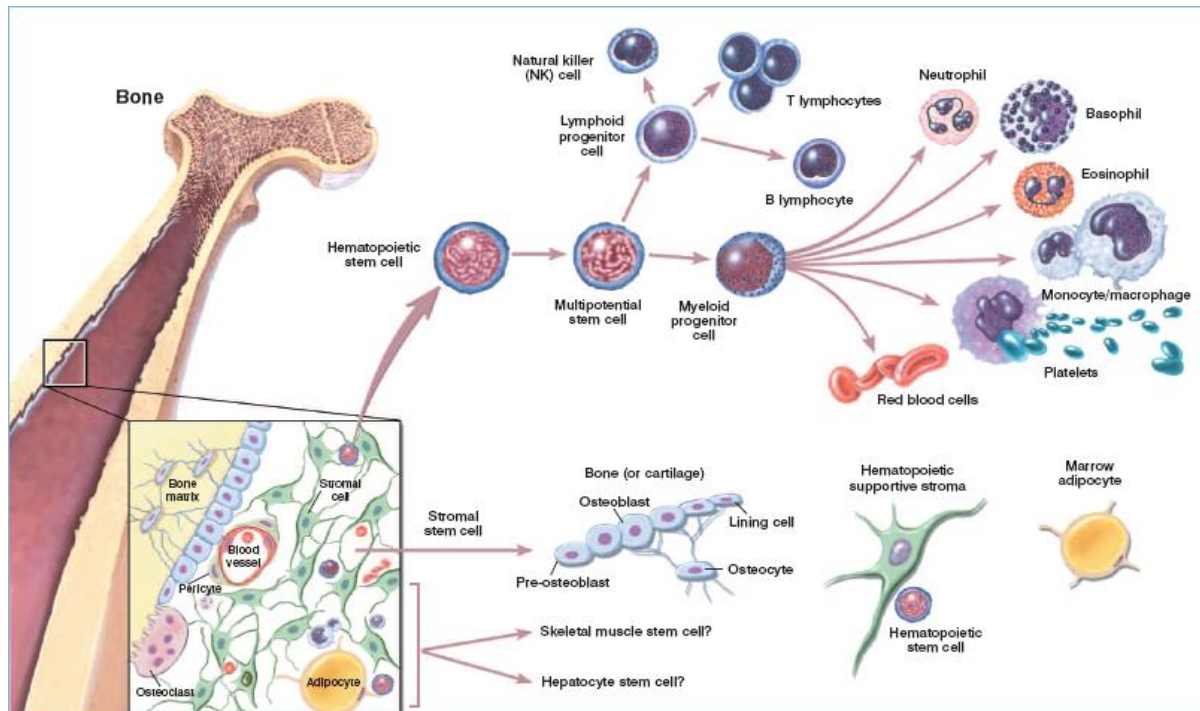

**Figure 1.3: Shifting sites of hematopoiesis across different developmental stages in *Mus musculus*** Hematopoiesis in mice occurs in two successive waves, primitive and definitive. The primitive wave of hematopoiesis occurs in the extra-embryonic yolk sac around E7.5, which is then followed by the definitive wave of hematopoiesis that occurs in parallel in several tissues such as AGM (Aorta-Gonad Mesonephros), placenta and fetal liver by E10.5 (Modified from Luis et. al. ,2012).

### 1.2.2.3.1 Mammalian hematopoietic lineages

All terminally differentiated blood cells are ultimately derived from a pool of HSCs which can be further classified into two categories – long-term reconstituting HSCs (LT-HSCs) and short-term reconstituting HSCs (ST-HSCs). LT-HSCs are defined by their self-renewability and potency to differentiate to all lineages throughout life, whereas ST-HSCs have limited ability to self-renew. ST-HSCs differentiate to generate multipotent progenitors (MPPs). MPPs lose their differentiation potential as they progressively generate blood cells of the Common

Myeloid Progenitor (CMP), Common Lymphoid Progenitors (CLP), Megakaryocyte-erythroid (MEP) and Granulocyte-Macrophage Progenitor (GMP) lineages (Wilson and Trumpp, 2006) (Refer Figure 1.4).

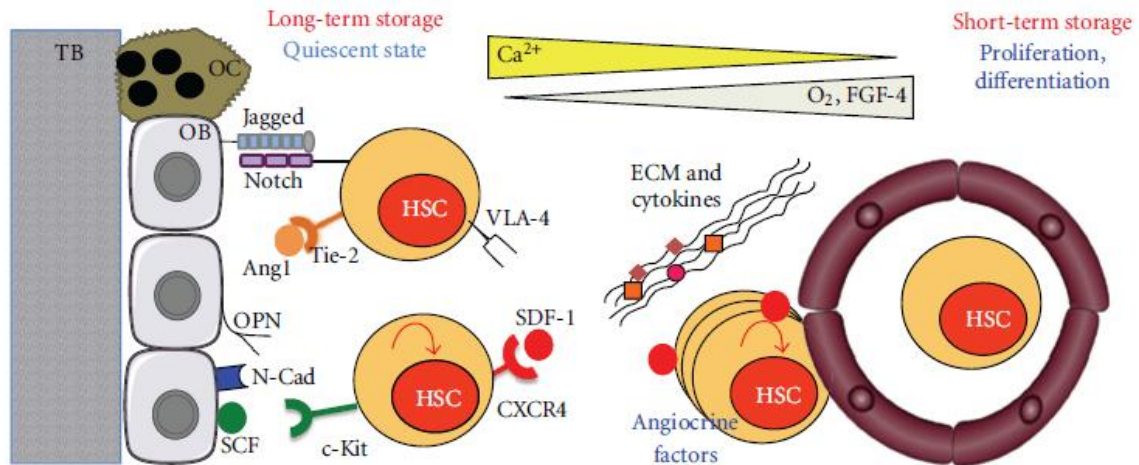

**Figure 1.4: Bone marrow hematopoiesis.** Hematopoietic stem cells in the bone marrow contribute to the production of an organized and hierarchical set of lymphoid and myeloid progenitor populations. These, further give rise to differentiated blood cell lineages. The lymphoid progenitors are devoted to the production of T-lymphocytes and B-lymphocytes whereas the myeloid progenitors give rise to an array of blood cells such as neutrophils, basophils, eosinophils, macrophages and platelets (*Modified from Winslow and Kibiuk, 2001*).

### 1.3 The hematopoietic stem cell niche

Niches are local tissue microenvironments (reviewed in Morrison and Scadden, 2014) that play a critical role in regulation of the balance between stemness and differentiation of HSCs for maintenance of tissue homeostasis. HSCs in the bone marrow preferentially reside in two niches, either in the osteoblastic niche comprising osteoblasts and stromal cells or in the vascular niche comprising sinusoidal endothelial cells. The osteoblastic niche is the hub of signalling pathways such as BMP4 pathway and Notch pathway which act in concert for maintenance of stem cells in a quiescent microenvironment. Endothelial niche, commonly

referred to as the vascular niche, plays an important role in promotion of hematopoietic progenitor cell proliferation, differentiation and migration (Yin and Li, 2006; Guerrouahen, 2011). In response to stress, hematopoiesis tends to shift to other sites such as spleen and is termed as extramedullary hematopoiesis (Morrison and Scadden, 2014) (Refer Figure 1.5).



**Figure 1.5: Niches of the bone marrow.** HSCs in the bone marrow reside in two niches: endosteal niche and the vascular niche. HSCs interact with osteoblasts (OB) and osteoclasts (OC), which are components of the endosteal niche. The endosteal niche provides a hypoxic microenvironment that is ideal for long-term maintenance of HSCs in their quiescent state. Several signalling molecules such as Jagged, angiopoietin, BMP4 act in concert to maintain HSCs' quiescence. On the other hand, the vascular niche is oxygen-rich and consists of sinusoidal endothelial cells and consists of an array of angiocrine factors. The vascular niche primarily functions to promote proliferation and differentiation of actively cycling, short-term HSCs (Modified from Guerrouahen, 2011).

#### 1.4 Signalling pathways involved in mouse hematopoiesis

Blood cell development is controlled by various factors, most of which are conserved from flies to mammals. Though signalling pathways seem to act independently, there exists potential cross-talk among them. Establishment of a functional blood system requires a tightly regulated interplay of various signalling pathways. The key signalling pathways regulating the process of hematopoiesis are described below:

### 1.4.1 Wnt pathway

Wnt signalling is a critical regulator of self-renewal and differentiation (Lento et. al., 2014) and regulates hematopoiesis in a dose-dependent fashion (Luis et. al., 2011). It maintains the HSCs in the bone marrow compartment and is involved in the development of mature lymphocytes. Like other signalling pathways, Wnt signalling has also been studied in the context of cancers of the blood system (Lento et. al., 2013). Uncontrolled activation of the pathway or deletion of any signalling component often results in chronic myelogenous leukemia (Jamieson et. al., 2004) or T-cell acute lymphoblastic leukemia and lymphoma (Guo et. al., 2007). Thus to conclude, Wnt signalling is involved in hematopoietic development and oncogenesis, and this highlights the crucial role of this signalling pathway (Refer Figure 1.6).

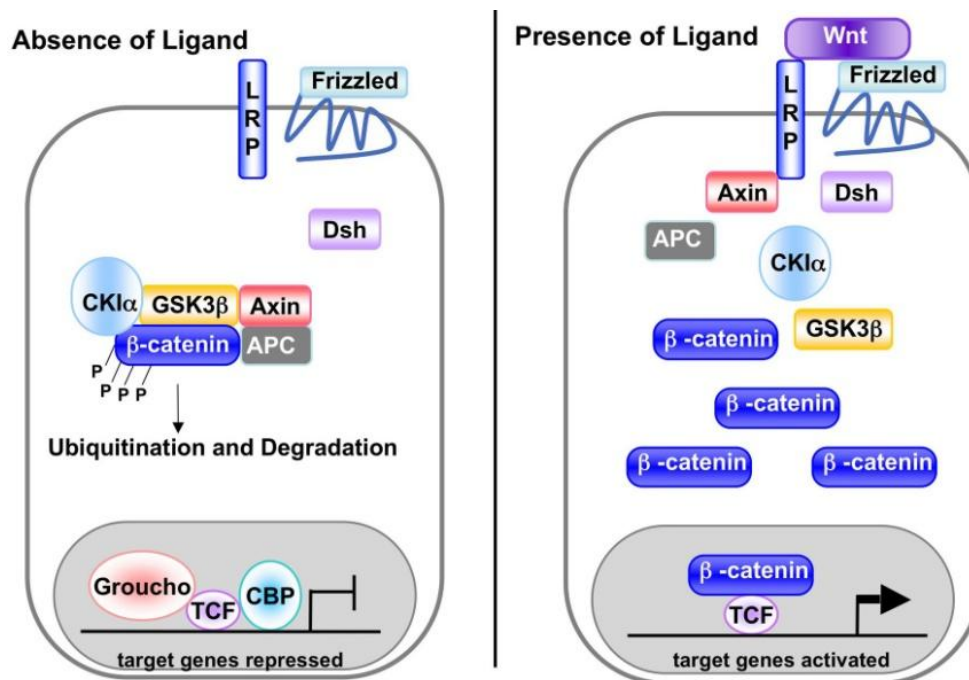
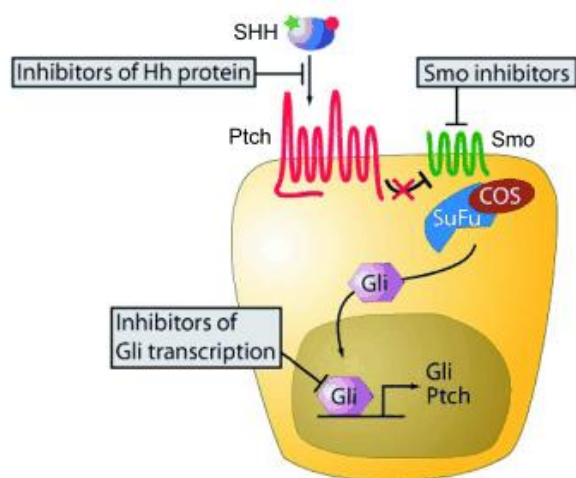

**Figure 1.6: Schematic representing Wnt signalling pathway.** In the absence of Wnt ligand (figure on left), the destruction complex comprising Axin, APC, GSK3 $\beta$  and CKI $\alpha$ ; hyperphosphorylate  $\beta$ -catenin which is degraded by the ubiquitin proteasome system. Binding of ligand (figure on right) leads to stabilization of hyperphosphorylated  $\beta$ -catenin and allows its translocation to the nucleus for mediating transcription of downstream target genes (Modified from [www.wormbook.org](http://www.wormbook.org)).

### 1.4.2 Hedgehog pathway

Hedgehog family consists of secreted proteins such as Sonic Hedgehog (Shh), Desert Hedgehog (Dhh) and Indian Hedgehog (Ihh), which bind to surface receptor Patched (Ptch) (Campbell C et. al., 2008). Patched negatively regulates the activity of a surface protein Smoothed (Smo). Binding of the secreted ligand to the Patched receptor, relieves Smoothed of the negative regulation, allowing it to activate Glioblastoma family (Gli) proteins, which act as transcription factors for expression of target genes such as Cyclin D1, Cyclin E, c-myc, Patched, Snail, VEGF, etc. (Trowbridge et. al., 2000) (Refer Figure 1.7).

Hedgehog pathway regulates important processes such as embryonic development (Caro and Low, 2010), tissue patterning (Varjosalo and Taipale, 2008) and repair (Tsonis et. al., 2004; Gupta et. al., 2010) organogenesis (Xie et. al., 2003; Franco et. al., 2012) and maintenance of stem cells (Watabe et. al., 2009). In addition, the Hedgehog pathway has been well studied in the context of normal as well as malignant hematopoiesis (Irvine et. al., 2012). Aberrant activation of the Hedgehog pathway contributes to the pathobiology of several hematological neoplasms such as B-cell neoplasms, T-cell neoplasms, chronic myelogenous leukemias and acute leukemias (Young et. al., 2012).



**Figure 1.7: Schematic representing Hedgehog signalling pathway**

(Modified from [www.otavachemicals.com](http://www.otavachemicals.com))



### 1.4.3 TGF- $\beta$ pathway

For a long period of time, TGF- $\beta$  signalling has been described as a negative regulator of hematopoiesis that functions to inhibit proliferation of cells of the hematopoietic lineages *in vitro* (Fortunel et. al., 2000). Relatively recent studies have highlighted the importance of TGF- $\beta$  signalling *in vivo* and *in vitro*. Like other signalling modules operating in the bone marrow, TGF- $\beta$  signalling functions in a context-dependent manner and plays an essential role in HSC generation or specification (Larsson and Karlsson, 2005).

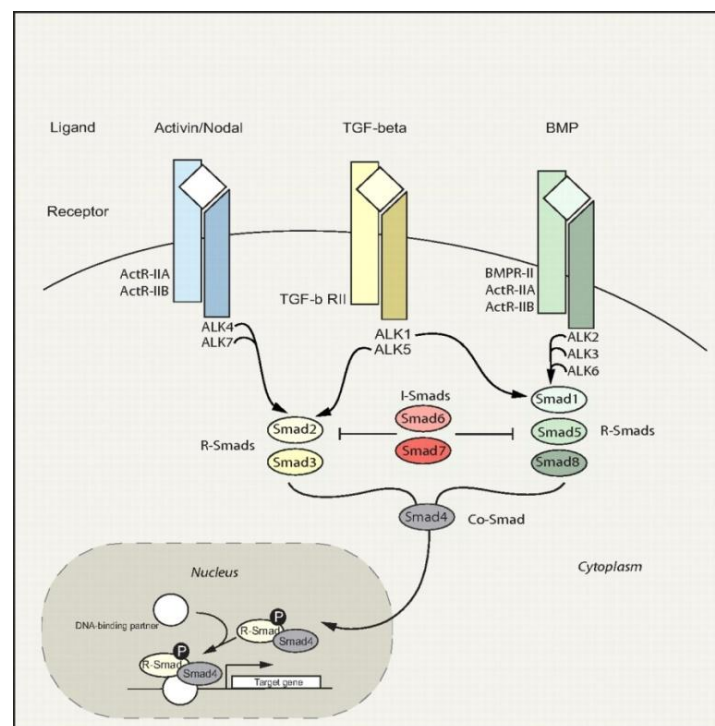

**Figure 1.8: Schematic representing TGF- $\beta$  signalling pathway.** The TGF- $\beta$  signalling pathway gets activated by a variety of ligands (rhombus shaped) including activins and related proteins, bone morphogenetic proteins (BMPs) and TGF- $\beta$ . Upon ligand binding, transmembrane receptor serine/threonine kinase type II recruits receptor type I and induces transphosphorylation. Activated type I receptors, phosphorylate the C-terminal serine residues of selected Smads, which are referred to as receptor-activated Smads or R-Smads (Smad-1, 2, 3, 5 and 8). These R-Smads associate with common partner Smad, also known as Co-Smad (Smad-4) and translocate to the nucleus, if not inhibited by the I-Smads such as Smad 6 (shown in pink) and Smad 7 (shown in red). The complex of R-Smad and Co-Smad effects transcription of target genes involved in processes such as proliferation, differentiation and migration (Modified from Ulrika et. al., 2008).

Knockout mouse models of TGF- $\beta$  isoforms and their receptors are early embryonic lethal, therefore, determining the role of this multifunctional cytokine signalling *in vivo* had

been hindered for a long time (Larsson et. al., 2003; Soderberg et. al., 2009). Recently, conditional knockout mouse models were generated. Analyses of these models revealed that TGF-  $\beta$  is an important regulator of hematopoiesis *in vivo* and any perturbation in this pathway may induce leukemogenesis (Kim and Letterio, 2003). Cancers of the blood system usually stem from mutation or deletion of members of the TGF-  $\beta$  superfamily by oncoproteins, which suggests a tumor-suppressing role for this pathway.

#### **1.4.4 JAK STAT Pathway**

“Janus kinase/signal transducers and activators of transcription” (JAK/STAT), signalling begins with the association of extracellular growth factors and cytokines to their respective transmembrane receptors. Ligand binding brings about a change in the conformation of the Janus kinase associated receptors leading to their dimerization. This prompts their proximity induced trans-phosphorylation that further results in activation of STAT molecules, facilitating their dimerization, resulting in their nuclear translocation and DNA binding activity (Villarino and Shea, 2015) (Refer Figure 1.9).

The JAK/STAT pathway is essential for development and homeostasis and is the principal signalling mechanism for a wide array of cytokines and growth factors. JAK activation stimulates an array of cellular functions such as proliferation, differentiation, migration and apoptosis which are critical for implementation of several biological processes (Rawlings et. al., 2004).

Analysis of JAK/STAT pathway has yielded new insights into hematopoiesis and hematopoietic disorders. The JAK/STAT pathway is widely used by several hematological factors; hence, it is not surprising that dysregulation of this pathway has been implicated in several hematological malignancies.



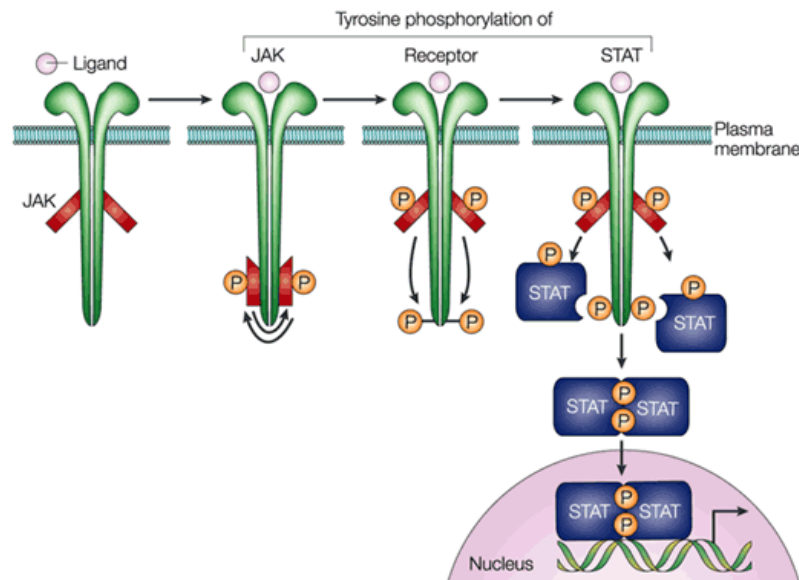
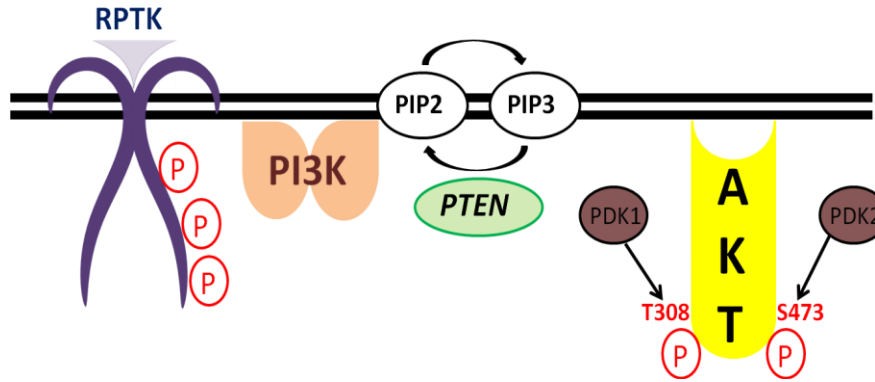

**Figure 1.9: Schematic representing JAK/STAT signalling pathway.** Binding of ligand (cytokines or growth factors) induces dimerization followed by trans-phosphorylation of receptors associated with Janus kinases. Phosphorylated receptors activate SH2-containing STATs that eventually translocate to the nucleus for regulation of target gene expression. Dysregulation of JAK/STAT signalling leads to cancer. Usage of Janus kinase inhibitors could prove to be effective in treatment of aberrant cytokine signalling driven hematological neoplasms (*Modified from Levy and Darnell, 2002*).

Aberrant activation of JAKs and STATs results in a variety of lymphomas and leukemias. Abrogation of this pathway is seen to manifest in various diseases such as severe combined immunodeficiency (SCID), acute myeloid leukemia (AML), benign erythrocytosis, Fanconi anaemia, etc (Ward and Yoshimura, 2000).

#### 1.4.5 PI3K/AKT pathway

Besides having well established roles in cell growth, proliferation and survival, the phosphoinositide 3-kinase-Akt (PI3K/Akt) pathway has very important roles to play in normal as well as malignant hematopoiesis. Activation of growth factor receptors brings about recruitment of PI3K to the plasma membrane for phosphorylation of PIP2 to PIP3. This leads to the downstream activation of a serine/threonine kinase, Akt, which is a major effector of this pathway (Refer Figure 1.10). Dysregulation of this pathway is known to cause several cancers, namely, breast cancer, lung cancer and colon carcinomas (Kharas and Gritsman, 2010).



**Figure 1.10: PI3K/Akt pathway and the consequences of its aberrant functioning** Receptor protein tyrosine kinase (RPTK) bound to growth factor triggers activation of PI3K for conversion of PIP2 to PIP3. PTEN, a phosphatase, converts PIP3 back to PIP2, facilitating phosphorylation of serine/threonine kinase Akt at residues Threonine 308 or Serine 473 by PDK1 or PDK2, respectively. PI3K/Akt pathway plays a well-known role in normal as well as malignant hematopoiesis. Constitutive activation of the Akt (Serine 473 phosphorylation) inhibits translocation of FoxO transcription factor to the nucleus. Nuclear exclusion of FoxO leads to oxidative stress causing premature stem cell exhaustion, thus, resulting in terminal differentiation of blood cells.

A tight regulation of the PI3K/Akt pathway has profound effects on HSC maintenance and quiescence. HSCs heavily rely on Phosphatase and Tensin Homolog (PTEN), a negative regulator of the Akt pathway, for maintenance of their self-renewal ability. In PTEN knockout mice, several hematopoietic abnormalities manifest in the presence of hyperactive Akt suggesting that PI3K/Akt pathway is crucial for maintenance of HSCs. Constitutive activation of Akt, the critical downstream activator of PI3K pathway, leads to exhaustion of the stem cell pool and induces myeloproliferative disorder in mice. Owing to genomic instability, myeloproliferative disorder in mice can rapidly progress to acute myeloid leukemia (AML) or T-cell acute lymphoid leukemia (T-ALL) (Warr and Passague, 2011). Thus, trying Akt as a potential therapeutic target for treatment of various myeloid and lymphoid leukemias could be an interesting avenue of future investigation.

#### 1.4.6 Notch Pathway

The Notch pathway is an evolutionary conserved pathway that is critical for cell fate determination and maintenance of tissue homeostasis in multicellular organisms (Bigas and Espinosa, 2012). In mammals, the Notch family consists of four proteins, viz., Notch 1, 2, 3 and

4 that are expressed on the surface of the cell and these interact with a set of ligands, namely, Jagged 1 and 2 and Delta 1, 3 and 4 (Zhou and Liu, 2014). Receptor-ligand binding induces two successive cleavage events of the Notch Intracellular Domain (NICD), mediated by the ADAM family and  $\gamma$ -secretase complex respectively, allowing translocation of NICD to the nucleus to effect transcription of essential target genes (Hafeez and Mukhtar, 2010) (Refer Figure 1.11).

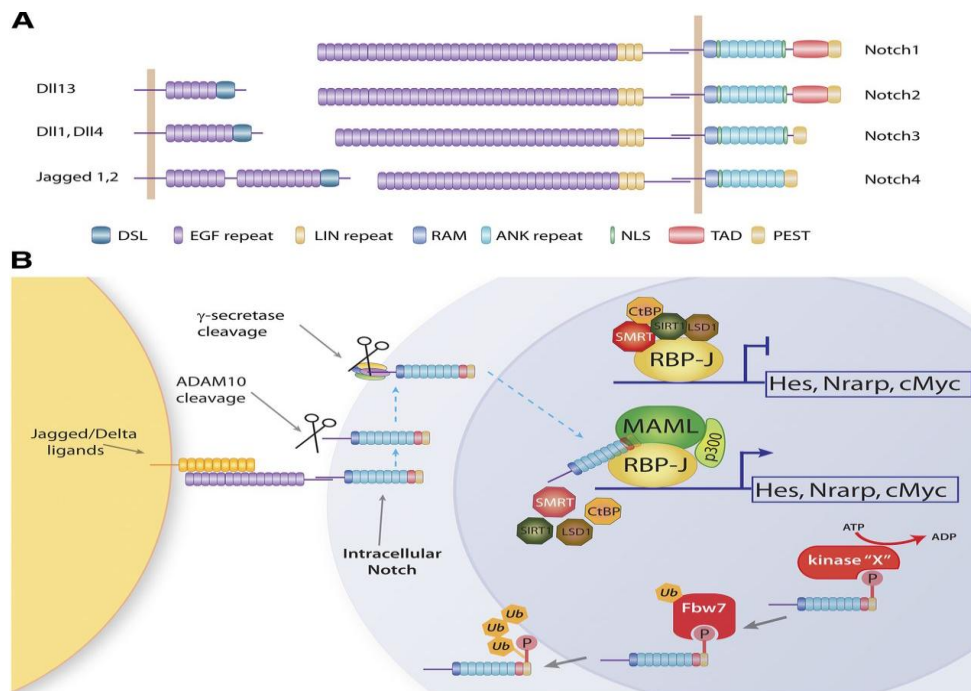

**Figure 1.11: Notch signalling in mammals.** **A**) The Notch family: The Notch family ligands (Jagged-1 and 2, Delta 1,3 and 4) have an extracellular DSL (Delta Serrate and Lag-2) ligand that plays an important role in mediating ligand-receptor association. The extracellular domain of the receptors (Notch 1-4) has variable number of EGF-like repeats but 3 LIN repeats. The cytoplasmic domain of the receptors harbour RAM domain, nuclear localization signal (NLS), ankyrin repeats and a PEST domain. **B**) Binding of Notch ligand to its cognate receptor induces two successive cleavage events by ADAM family metalloprotease and  $\gamma$ -secretase complex, generating the NICD which translocates to the nucleus for displacement of corepressor complex and activation of target gene expression. Phosphorylation of the PEST domain of NICD leads to its subsequent degradation, thereby leading to signal attenuation (*Modified from Lobry et. al., 2013*).

The Notch pathway is critical for regulation of embryonic and adult hematopoiesis (Refer Figure 1.12). During embryonic development, Notch signalling plays an important role in specification of stem cell fate (Yu et. al., 2008). Analysis of zebrafish mutants has highlighted that Notch signalling mostly affects cell-fate decisions in the definitive hematopoietic phase and is essential for development of embryonic HSCs derived from the

same (Schwanbeck and Just, 2011). Notch signalling is indispensable for adult bone marrow hematopoiesis as it helps in HSC establishment and cell-lineage specification (Bigas et. al., 2012). Besides, it is the major form of communication between HSCs and components of the osteoblastic and endothelial niche (Schwanbeck and Just, 2011).

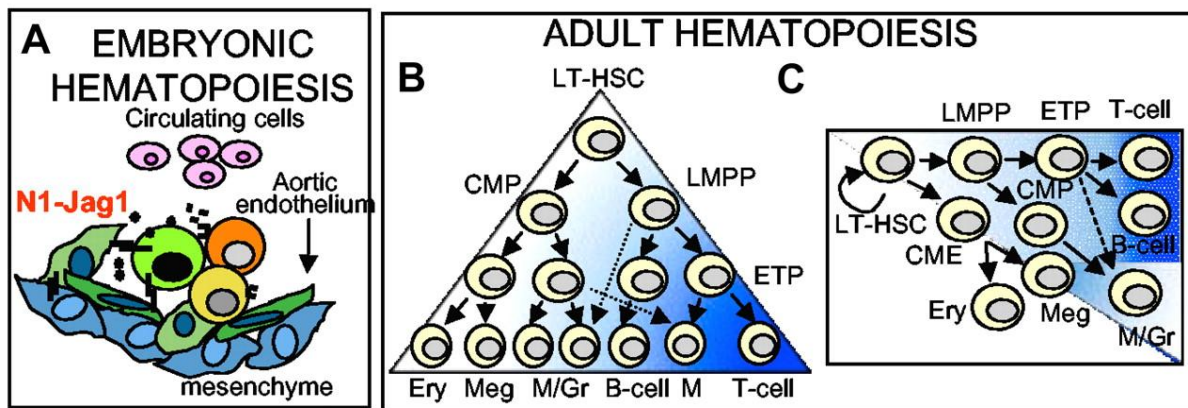

**Figure 1.12: Role of Notch signalling in embryonic and adult hematopoiesis.** **A) Embryonic hematopoiesis** Notch signalling plays an active role in the aorta-gonad mesonephros for establishment of HSCs. The key receptor-ligand interaction favouring hematopoietic development is Notch 1 (N1) and Jagged 1 (Jag1) combination (shown in red). **B) Adult hematopoiesis** Notch signalling acts in a gradient (shown in blue) and is involved at multiple steps of hematopoiesis. In the adult bone marrow, it plays an important role in lineage specification. **C) A hematopoietic potential restriction model** Depending on the dosage of Notch activity, the capacity of a cell to contribute to different lineages gets progressively restricted. (Modified from Bigas and Espinosa, 2012).

Apart from its role in determining cellular identity, Notch signalling plays an important role in T-cell development. Analysis of expression profiles of Notch receptors, ligands and target genes in adult murine thymus has shown that Notch signalling is critical for regulation of stage-specific T-cell development (Hasserjian et. al., 1996; Taghon et.al., 2012).

Up-regulation or down-regulation of Notch signalling has been implicated in several hematological malignancies. Loss of activity mutation of Notch-1 in CD34+ progenitor culture results in chronic myelomonocytic leukemia (CMML) (Sengupta et. al., 2007). It has been shown that increasing Notch-1 mediated signalling by overexpressing NICD proves to be effective in suppressing the proliferation rate of human chronic myeloid leukemia cell line K562 (Yin DD et. al., 2009). On the other hand, analysis of several murine and human tumors shows that constitutive activation of Notch-1 results in T-cell acute lymphoblastic leukemia (T-

ALL) (Aster et. al., 2011; Klinakis et. al., 2011; Schwanbeck and Just, 2011). Thus, Notch signalling functions in a dose-dependent manner to maintain the balance between HSCs and mature blood cells; in other words, it maintains hematopoietic stem cells and progenitor cells in their undifferentiated state (Warr and Passegue, 2011).

#### **1.4.7 Ubiquitin Proteasome – COP9 Signalosome Pathway**

Precise control of the ubiquitin-proteasome system (UPS) is crucial for the execution of proper developmental programs. Post-translational modifications, such as ubiquitination modulate the stability and function of important factors that regulate stem cell behaviour. The UPS functions to maintain the balance between quiescence, self-renewal and differentiation in HSCs. Loss of activity of the UPS system leads to premature exhaustion of stem cell pool and causes hematopoietic failure or cancer. Analyses of E3 ligase knockout mouse models have highlighted the importance of UPS in adult stem cell biology. Mutations in SCF, an E3 ligase, results in T-cell acute lymphoblastic leukemia (T-ALL). Dysregulation of the UPS is seen in cancers, neurodegenerative diseases, immune disorders and leads to the formation of tumor-initiating cells. Development of UPS inhibitors for treatment of such disorders can prove to be effective (Strikoudis and Aifantis, 2014).

The COP9 signalosome is a novel protein assembly that acts at the interface of signal transduction and UPS. It is a highly conserved eight subunit protein complex that is involved in multifaceted development process through regulating proteasome-mediated protein degradation. This nuclear-enriched protein complex has 8 distinct subunits, designated CSN1 to CSN8, both subunit composition and subunit amino acid sequences have been highly conserved in diverse organisms implying a conserved cellular function for the COP9 signalosome. The COP9 signalosome has a global role in signal transduction and is involved in the control of multiple signalling pathways, but the only biochemical function ascribed to it, is the

isopeptidase activity of CSN that is responsible for removal of ubiquitin like protein NEDD8 from CULLIN proteins (Otschir et. al., 2002).

In summary, various inputs from signalling pathways such as Wnt, Hedgehog, TGF- $\beta$ , Notch, JAK/STAT, PI3K/Akt and ubiquitin-proteasome-COP9 signalosome pathway act in concert to maintain and regulate bone marrow hematopoiesis.

### ***1.5 Hematological neoplasms – Disease perspective***

Interactions between bone marrow and its niches (endosteal and vascular) is critical for maintenance of bone marrow homeostasis and is known to be mediated by multiple signalling axes. Alterations in the composition of the bone marrow or its supporting microenvironment that affect homeostasis, i.e., disruption of any key player of hematopoiesis can lead to hematological neoplasms. *Mus musculus* has proven to be an extremely valuable model for studying hematopoietic development and for unravelling the complex cellular circuitries that give rise to a leukemic condition.

Hematological neoplasms are a heterogeneous group of cancers of the blood-forming tissue, such as bone marrow or cells of the immune system. They can be grouped into lymphomas, myeloproliferative neoplasms (MPNs) and myelodysplastic syndromes (MDS) with multiple subtypes as shown in Figure 1.13. Leukemia is the cancer of the blood and bone marrow which is characterized by massive and abnormal production of WBCs leading to impairment in the production of RBCs and platelets. It can be categorised into acute or chronic based on the rate of progression of the disease. Acute leukemias progress rapidly whereas chronic leukemias progress more slowly. A burst in the rate of production of blast cells of lymphoid or myeloid lineage leads to lymphoblastic or myeloblastic leukemia (Zhang and Wang, 2014). On the other hand, lymphoma is a cancer specific to the lymphatic system which is defined by rapid production and collection of abnormal lymphocytes in the lymph nodes. It

can be classified into two types: Hodgkin's and Non-Hodgkin's lymphoma (Tripodo et. al., 2013; Marinaccio et. al. 2014). Aberrant proliferation of plasma cells is termed as multiple myeloma (Meldi and Figueora, 2014).

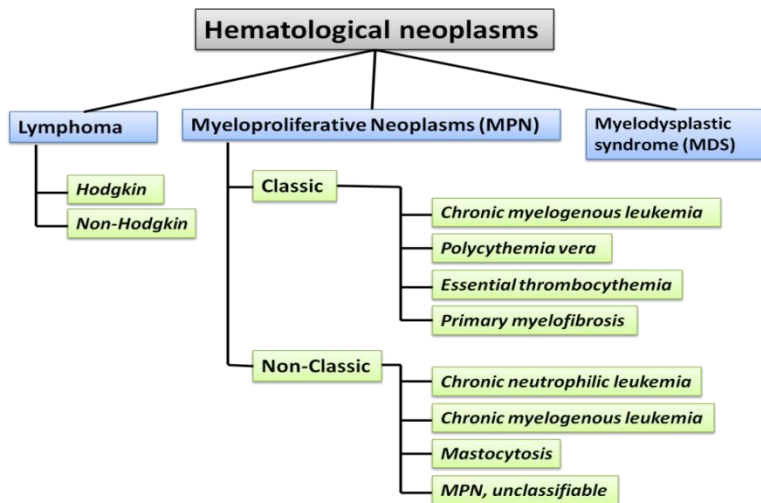

**Figure 1.13: Schematic representing different types of hematological neoplasms.**

Not much is known about the treatment of such extremely complex blood disorders. Complete peripheral blood counts and assessment of bone marrow cellularity aid in initial evaluation of aberrant hematopoiesis. Patients suffering from hematological neoplasms undergo several rounds of chemotherapy, blood transfusions or bone marrow transplantations. Manipulation of the bone marrow or its stroma brings about changes such as fibrosis, angiogenesis and osteosclerosis, which play an active role in pathogenesis and disease progression. Thus, use of tyrosine kinase inhibitors or proteasomal inhibitors or immunomodulatory agents that focus on impairing the signalling axes that mediate cross-talk between neoplastic cell populations and their microenvironments should prove to be effective (Tripodo et. al., 2013). There is increasing awareness of the role of intracellular transport processes in signal modulation during hematopoiesis and attention is now focussed on identifying suitable targets for therapeutic purposes.

## **1.6 Endosomes as signalling platforms**

Endosomes have been known to play a crucial role in receptor internalization for signal attenuation, but recent studies have highlighted that much of the signal activation and generation takes place at the surface of endosomes (Platta and Stenmark, 2011). Endosomes constitute the intracellular signalling machinery of the cell that serves the purpose of ‘meeting grounds’ for various signalling components. Endocytosis occurs in several ways and brings about spatio-temporal regulation of different signals. It could be clathrin-dependent or independent endocytosis and depending on the cellular input, it could lead to activation or down-regulation of a given signalling pathway (Mayor and Pagano, 2007; Doherty and McMahon, 2009).

Enzymes or effectors localize specifically to the endosomes through endosome-associated adaptor proteins or scaffold proteins. By doing so, the limited area of the endosomal membrane facing the cytosol helps in the assembly of protein complexes, thereby serving the purpose of an ideal ‘physical platform’. Endosome-associated proteins can not only facilitate signal transduction of a particular pathway but also regulate interactions among different signalling pathways (Pawson et. al., 2007; Fehrenbacher et. al., 2009; Zastrow and Sorkin, 2009). Endosomes facilitate differential regulation of various signalling pathways depending on the cellular and biological context. Perturbation of the endosomes or endosomal routes is likely to take a toll on various signalling pathways, thereby affecting an array of cellular functions.

## **1.7 A key player in hematopoiesis – Asrij**

To understand the endosomal regulation of hematopoiesis in mouse, we have focused our analysis on a blood-specific endosomal protein, Asrij, that is expressed in the hematopoietic system. Asrij was identified in our laboratory, in a gene-trap screen as a protein with high levels of expression in mouse embryonic stem cells which was restricted to the cardiovascular and



blood lineages upon differentiation (Mukhopadhyay et. al., 2003). Immunostaining analyses revealed that Asrij is expressed in mouse yolk sac and embryonic blood islands and vessels. Its expression was seen to overlap with that of VEGF-RII/Flk-1 and PECAM/CD31.

*Drosophila* Asrij found by sequence homology was seen to be expressed in pole cells, trachea and hemocytes (Inamdar, 2003). Asrij, a pan hemocyte marker, expressed in all three zones of the primary lymph gland lobes, is a key player of *Drosophila* hematopoiesis. Asrij null flies which were generated by P-element mediated mutagenesis display aberrant hematopoietic phenotypes such as enlargement of primary and secondary lobes of the lymph gland and increased proliferation and differentiation of hemocytes. Asrij is required for niche maintenance and has a conserved role in maintaining the balance between stemness and differentiation, mediated by its OCIA (Ovarian Carcinoma Immunoreactive Antigen) domain. It brings about endocytic regulation of Notch signalling for controlled crystal cell specification (Kulkarni, Khadilkar et. al., 2011). Apart from its function in hematopoiesis, Asrij also plays a role in *Drosophila* immunity by regulating the Toll and Imd pathways (Vani Kulkarni thesis, 2010).

Asrij facilitates the endosomal activation of STAT3 and also regulates Notch signalling to maintain blood cell homeostasis in *Drosophila*. Asrij was shown to interact with ARF1(ADP-Ribosylation Factor-1) in a yeast two-hybrid screen earlier (Giot et. al., 2003) which was later validated by immunofluorescence and co-immunoprecipitation (Vani Kulkarni thesis, 2010). The Asrij-ARF1 axes is integral to endosomal regulation of multiple signalling pathways such as JAK/STAT, Notch, PDGF-VEGF for maintenance of blood cell homeostasis (Khadilkar thesis; Khadilkar et. al., 2014). Previous studies have shown that Asrij biochemically interacts with STAT3 and aids in its phosphorylation, which is important for maintenance of stemness in mouse embryonic stem cells (Sinha thesis; Sinha et. al., 2013). Interestingly, mouse Asrij and *Drosophila* Asrij are homologs and mouse Asrij can maintain

the stem cell state in *Drosophila* (Khadilkar thesis; Khadilkar et. al. 2014). This study focuses on understanding the role of Asrij in mouse hematopoietic development.

### **1.8 Aims of the present study**

The major aim of the present study was to characterize the mechanism of endosomal regulation of cellular signalling in the context of mouse hematopoiesis and development.

The specific aims of this study were:

In *Drosophila*:

- 1) To identify the interacting partners of Asrij using proteomics as a tool.**

In mouse:

- 2) To identify the role of Asrij in hematopoiesis**
- 3) To identify the signalling pathway(s) influenced by Asrij**
- 4) Phenotypic analysis of Asrij knockout mice tissues.**

### **1.9 Summary of the present study**

We found that the endocytic molecule Asrij has a conserved role in mediating control of signalling networks that act in concert to regulate hematopoiesis in vertebrates. Disruption of Asrij-governed endocytic circuitries can therefore result in hematological neoplasms. This study establishes a previously unrecognized role for Asrij in bone marrow hematopoiesis and that its deficiency results in hematological neoplasms in mice.

## **Chapter 2: Using proteomics to build the Asrij network**

### **2.1 Introduction**

#### **2.1.1 Endosomal regulation of hematopoiesis**

Hematopoietic stem cells in *Drosophila* and vertebrates give rise to an organised hierarchy of progenitors that eventually form an array of terminally differentiated cells which are responsible for life-long maintenance of the blood system. Vertebrate HSCs differentiate to form erythroid, myeloid, lymphoid and megakaryocytic lineages and the differentiation along each lineage is orchestrated by a team of transcription factors and signalling molecules. Owing to the high conservation of signalling pathways and proteins between *Drosophila* and vertebrate hematopoiesis, the lymph gland of the fruit fly is a relevant and well-accepted model for studying mechanisms underlying hematopoiesis.

Recent studies have shown that co-ordination and integration of various inputs from different signalling pathways takes place at the endosomes. Endosomal proteins are well-positioned to act as ‘active signalling platforms’ and facilitate cross-talk among different pathways (Sigismund et. al., 2012). Thus, these proteins could be potential regulators of various cellular processes including hematopoiesis.

#### **2.1.2 Understanding Asrij function using genetically modified *Drosophila melanogaster* lymph glands**

Asrij is an OCIA-domain containing protein whose role in endocytosis is largely unknown. In *Drosophila*, Asrij is required for hematopoietic niche maintenance and functions to maintain the balance between prohemocytes and hemocytes. *Drosophila* Asrij null flies

display aberrant hematopoietic phenotypes such as enlargement of primary and secondary lobes of the lymph gland, increased proliferation and differentiation. Previously, we have reported that Asrij interacts with a known endosomal protein ARF1 for regulation of *Drosophila* lymph gland hematopoiesis. Further, the Asrij-ARF1 axis actively regulates JAK/STAT, Notch and PDGF-VEGF signalling pathways for maintenance of blood cell homeostasis (Khadilkar et. al., 2014).

Asrij functions at multiple levels during hematopoiesis and this makes it difficult to dissect its exact mechanism of action. To fetch answers to the intriguing question as to how an endosomal protein Asrij can fine tune the delicate balance between stemness and differentiation, we opted to use a quantitative-proteomics based approach.

### **2.1.3 Advantages and challenges of proteomics study using *Drosophila melanogaster***

Proteomics is the large scale study of the structure and function of proteins. It helps in providing the entire complement of proteins in a cell at a given point of time (Graves et. al., 2002).

We opted for *Drosophila* lymph gland proteomics because hematopoiesis in *Drosophila* is far simpler than vertebrates and gives rise to namely three types of blood cells – plasmacytes, crystal cells and lamellocytes. Besides, *Drosophila* has limited gene redundancy as compared to vertebrates that facilitates easy analysis of gene function. Proteomics of the genetically modified lymph glands can not only help interrogate changes at the protein level but also help in finding several potential regulators of hematopoiesis whose activity might be Asrij-dependent. Finding these novel regulators can help unravel protein networks and circuitry that control hematopoiesis.

The most critical and challenging step is isolation of 1500 lymph glands from *Drosophila melanogaster* third instar larvae, owing to their small size and fragile nature of the lymph glands.

## **2.2 Materials and Methods**

### **2.2.1 Fly Stocks and Genetics**

Larvae were maintained on standard cornmeal food at 25 °C and were collected before pupariation. Canton-S was used as the wild-type reference strain. The following fly stocks were used: *arf<sup>9</sup>/arf<sup>9</sup>*, *UAS Dmarj*, *e33c-GAL4* (K.Anderson, NY).

### **2.2.2 Dissection and sample preparation for mass spectrometry**

Wandering third instar larvae were immobilized by cooling, pinned ventral side up and a longitudinal excision was made. Viscera and excess parts of body wall were removed; leaving a thin strip of body wall to which the dorsal vessel remained attached. The lymph gland having the primary lobes and secondary lobes intact was collected in PBS containing phenylmethanesulfonylfluoride (Catalogue No.: 36978, PMSF Protease Inhibitor, Thermo Scientific) in order to prevent proteases from degrading the tissue. Dissected lymph gland samples were stored at -80 °C.

### **2.2.3 Protein lysate preparation from *Drosophila melanogaster* lymph glands**

1500 lymph glands of wild type, *Asrij* mutant and *Asrij* over-expression third instar larvae (Refer Figure 2.1) were lysed in 0.5% SDS and homogenized by sonication. The lysates obtained were centrifuged at 13,000 rpm for 10 minutes at 4 °C followed by protein estimation of the supernatants using bicinchoninic acid (BCA) assay (Pierce, Thermo Scientific) for normalization on gel. Equivalent amounts of protein from each sample was reduced and

alkylated and then subjected to trypsin digestion (Catalogue No.:V511A, Sequencing Grade Modified Trypsin, Promega) in an enzyme and substrate ratio of 1:20 (w/w) at 37 °C for 16 hours. Trypsin digestion was done by Institute of Bioinformatics, Bangalore.

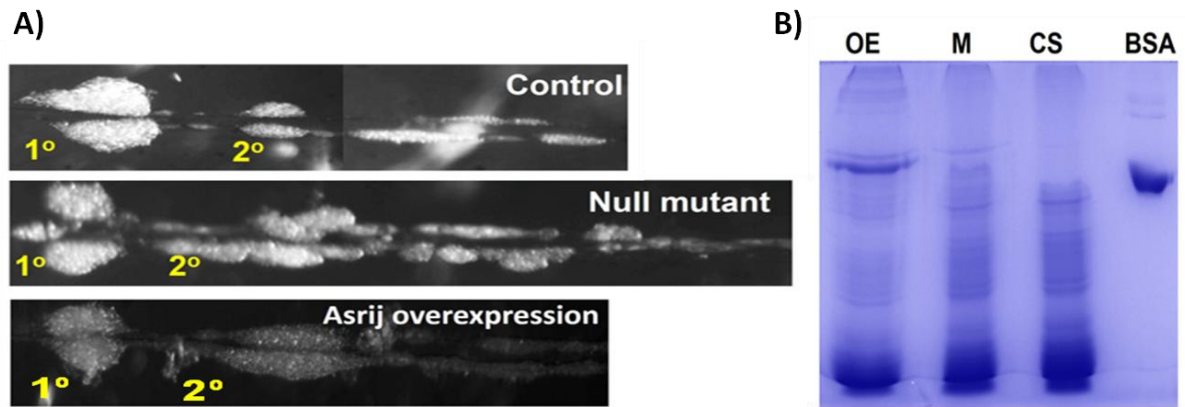

**Figure 2.1:** [A] Asrij mutant *Drosophila melanogaster* larval lymph glands were taken for iTRAQ-based quantitative proteomics. 1° and 2° represent the primary and secondary lobes of the respective lymph glands [B] Coomassie stained protein lysates of Asrij overexpression (OE), Asrij null mutant (M) and wild type (CS) lymph glands on SDS gel (Loading control taken was bovine serum albumin).

#### 2.2.4 iTRAQ labelling and LC with MS/MS

Trypsin digested samples were further processed by Institute of Bioinformatics as follows- The peptides generated from wild type, Asrij mutant and Asrij over-expression lymph gland samples were then labeled with iTRAQ 4-plex reagents (Catalogue No.: 4352135, Applied Biosystems, Foster City, CA, USA) as per manufacturer's protocol, yielding 114, 115 and 116 reporter ions, respectively. These iTRAQ labeled peptides were eventually pooled, reconstituted in SCX solvent A (10 mM potassium phosphate, 20% acetonitrile, pH 2.8) and subjected to strong cation exchange chromatography on a polysulfoethyl A column (200 x 2.1mm; 5µm; 200Å PolyLC, Columbia, MD) using Agilent's 1200 series HPLC system. Fractionation of peptides was carried out by a linear gradient of solvent B (350 mM KCl in solvent A) for 70 minutes at a flow rate of 200 µl per minute. The fractions thus collected, were dried in speedvac, reconstituted in 10 µl of 0.1% TFA and cleaned using C<sub>18</sub> stage tips prior to LC-MS/MS analysis.

Tandem mass spectrometric analysis of the iTRAQ labeled peptides was carried out using LTQ-Orbitrap Velos mass spectrometer (Thermo Scientific, Bremen, Germany) interfaced with Easy nanoLC II (previously Proxeon, Thermo Scientific, Bremen, Germany). The nanospray ionization source of the mass spectrometer was fitted with a 10  $\mu\text{m}$  emitter tip (New Objective, Woburn, MA) and maintained at 2000 V ion spray voltage. Peptide samples were loaded onto an enrichment column (2 cm  $\times$  75 $\mu\text{m}$ , Magic AQ C18 material 5 $\mu$  particle size, 100 Å pore size) in 0.1% formic acid, 5% acetonitrile for 15 min and peptide separation was carried out on analytical column (10 cm  $\times$  75 $\mu\text{m}$ , Magic AQ C18 material C18 material 5 $\mu$  particle size, 100 Å pore size) using a linear gradient of 7-35% solvent B (90% acetonitrile in 0.1% formic acid) for 60 minutes at a constant flow rate of 350 nl/minute. Data was acquired using Xcalibur 2.1 (Thermo Scientific, Bremen, Germany) in a data-dependent manner in the m/z range of 350 to 1800 at a mass resolution of 60,000 at 400 m/z at the MS level and 15,000 at 400 m/z at MS/MS level by targeting top 20 most abundant ions for fragmentation using higher energy collisional dissociation at 39% normalized collision energy. The dynamic exclusion option was enabled during data acquisition with exclusion duration of 60 seconds. Lock mass option was enabled for real time calibration using polycyclodimethylsiloxane (m/z, 415.12) ions.

### **2.2.5 Analysis of mass spectrometry data**

Analysis of data was done in collaboration with Institute of Bioinformatics, Bangalore. The mass spectrometric data was fed to SEQUEST and MASCOT search engines in the Proteome Discoverer software suite (Version 1.4.0.288, Thermo Scientific, Bremen, Germany) against the *Drosophila melanogaster* protein database from Flybase appended with the known contaminants. A precursor mass range of 350-8000 Da and a signal to noise of 1.5 was used for the searches. Search parameters included trypsin as the enzyme with maximum 1 missed cleavage allowed. Oxidation of methionine was set as dynamic modification while cysteine

alkylation and iTRAQ modification at N-terminus of the peptide and lysine were set as constant modifications. Mass deviation of up to 20 ppm and 0.1 Da were allowed for precursor and fragment ions, respectively. The relative expression of proteins was calculated based on the relative intensities of reporter ions for the corresponding peptides. False discovery rate cut-off of 1% was used for all the identifications.

## **2.3 Results**

### ***2.3.1 Gene ontology enrichment analyses highlights major molecular functions affected on perturbation of Asrij levels***

The differentially expressed proteins obtained from our analysis were categorized based on gene ontology annotation into biological processes, molecular functions and cellular localization using WEB-based Gene Set Analysis Toolkit (Refer Figure 2.2).



## Mutant vs. control

### A. Biological process

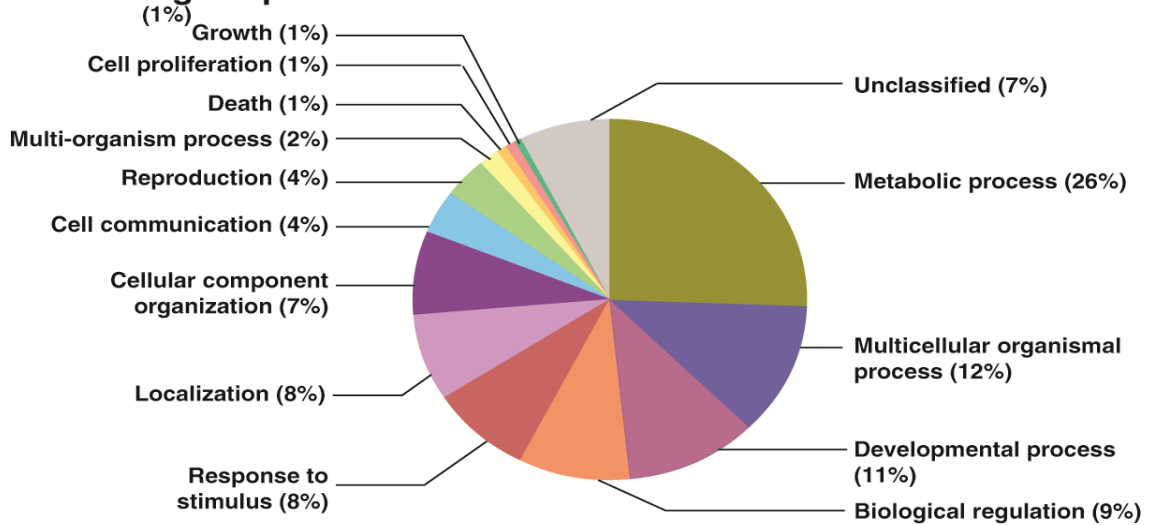

### B. Molecular Function

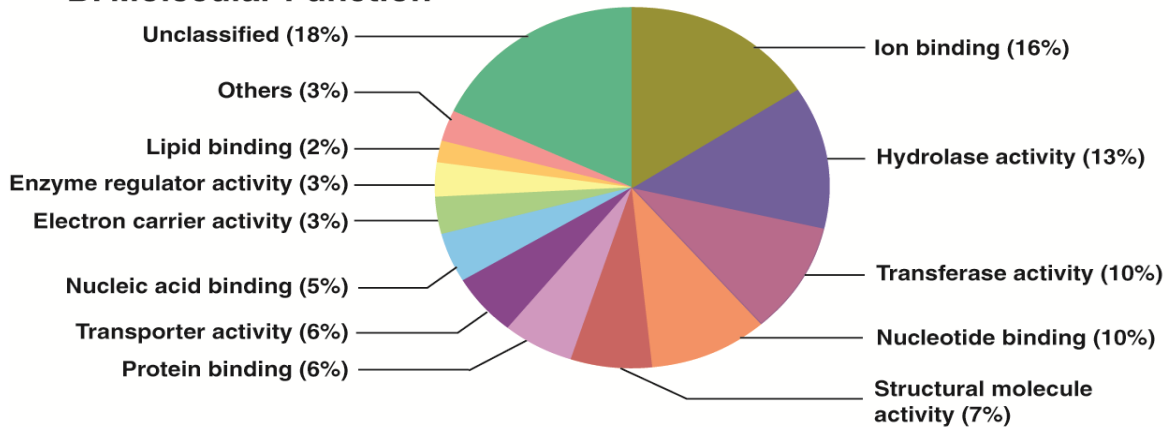

### C. Cellular component

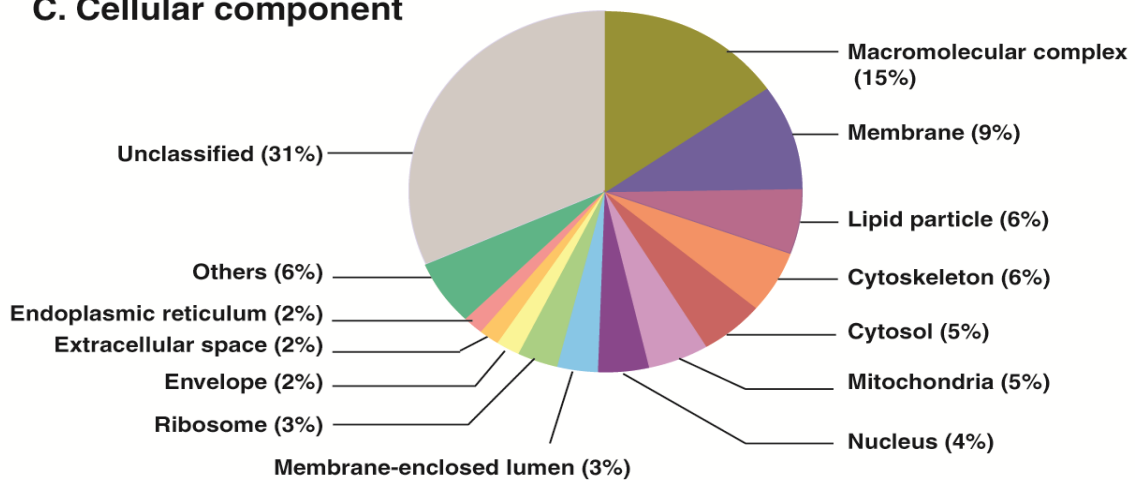

## Asrij overexpressed vs. control

### A. Biological process

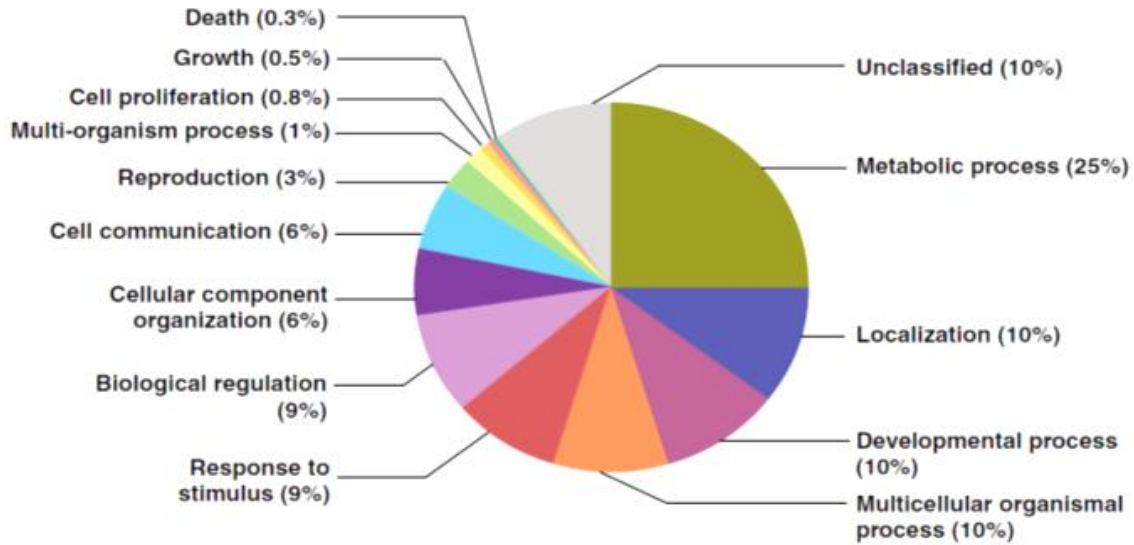

### B. Molecular Function

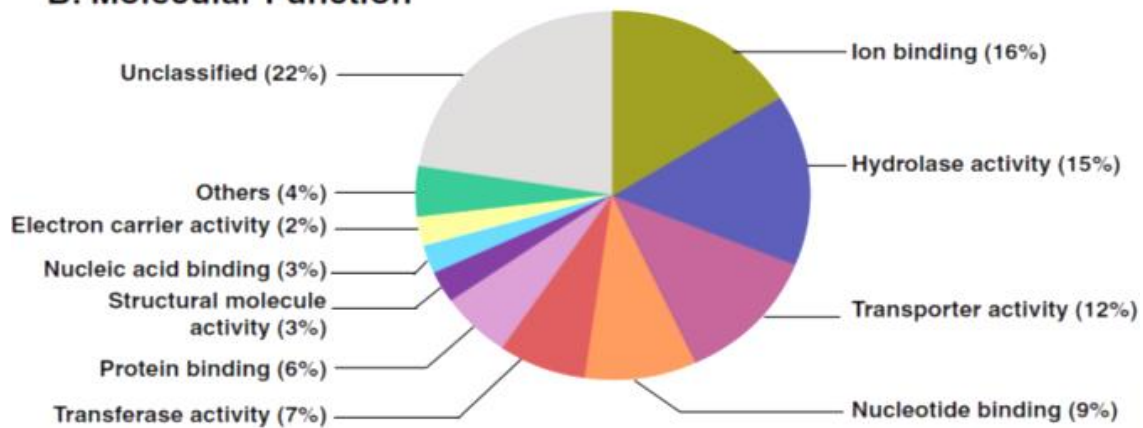

### C. Cellular component

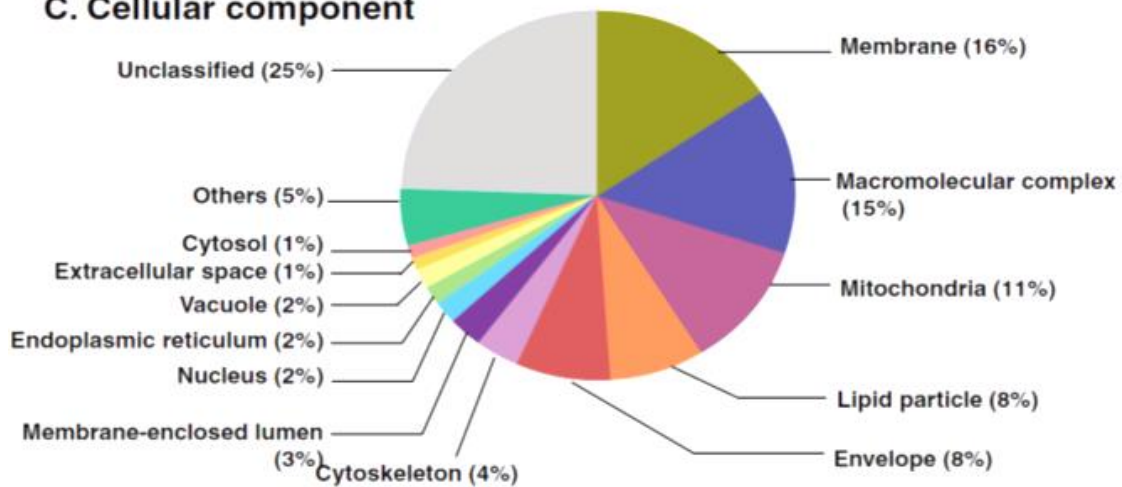

## Asrij overexpressed vs. mutant

### A. Biological process

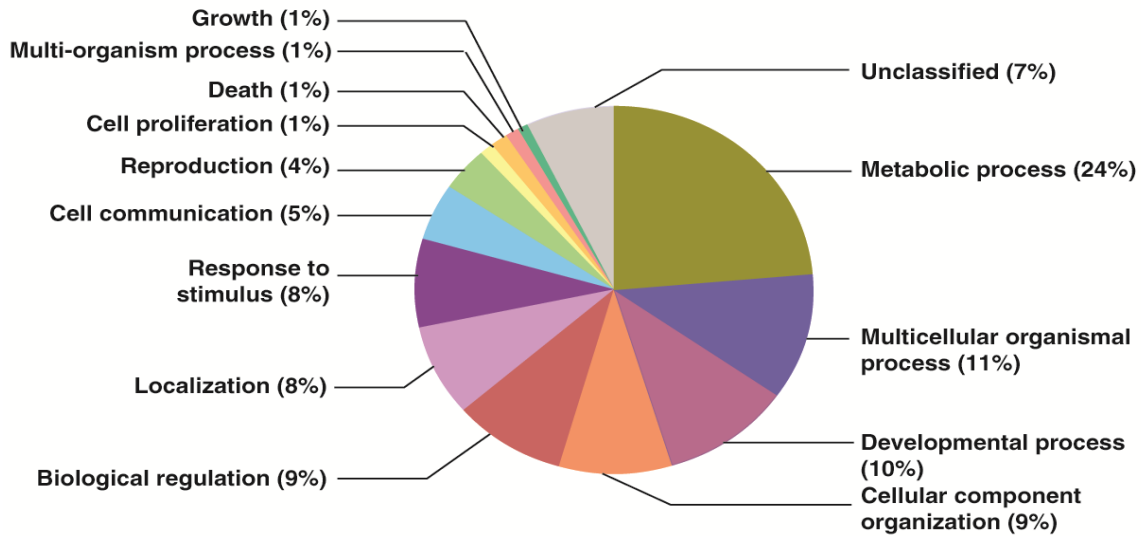

### B. Molecular Function

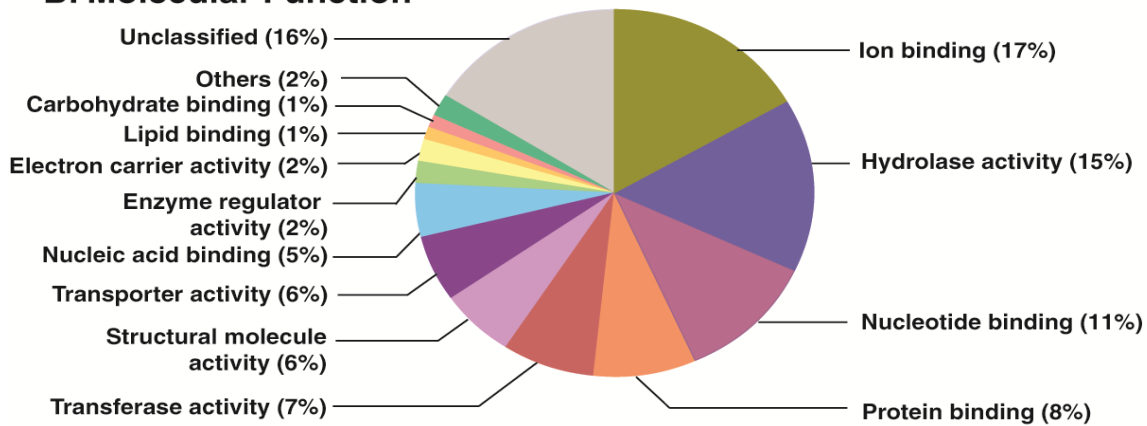

### C. Cellular component

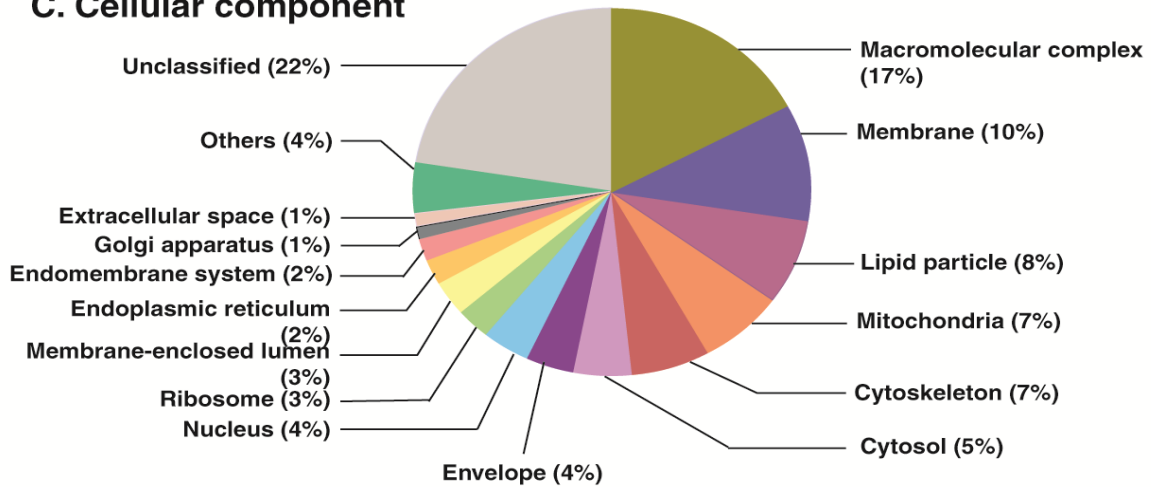

**Figure 2.2:** Gene ontology analysis of the lymph gland proteome of *Drosophila melanogaster* of Asrij mutant compared to wild type, Asrij overexpression compared to wild type and Asrij overexpression compared to Asrij mutant as an approach to study (A) biological processes (B) molecular functions and (C) cellular localization that are affected.

The differentially expressed proteins were also overlaid on various pathways on KEGG Pathway database using Pathway Architect module of GeneSpring (version 12.6) to assess the enrichment of pathways. Perturbation of the endocytic protein Asrij impinges upon several signalling pathways and affected an array of cellular processes. Metabolic and developmental processes, multicellular organismal processes and cellular component organization were few among the major processes affected in the mutant *Drosophila* lymph glands. The major molecular functions perturbed on Asrij knockout or overexpression were ion binding, transporter activity, protein binding, etc.

### ***2.3.2 Modulation of Asrij levels alters the protein landscapes of Drosophila melanogaster lymph glands***

Changes in transcript levels do not necessarily correspond to the significant changes in protein levels. Hence, understanding complex cellular mechanisms requires integration of data sets that combine protein expression, its relative abundance and sub-cellular localization. Studying this effectively requires a specialised high-throughput technique such as proteomics that allows one to interrogate changes at the protein levels with respect to a particular biological perturbation.

The proteome profile showed an abundance of 870 cellular proteins whose expression was Asrij dependent (Refer Figure 2.3).

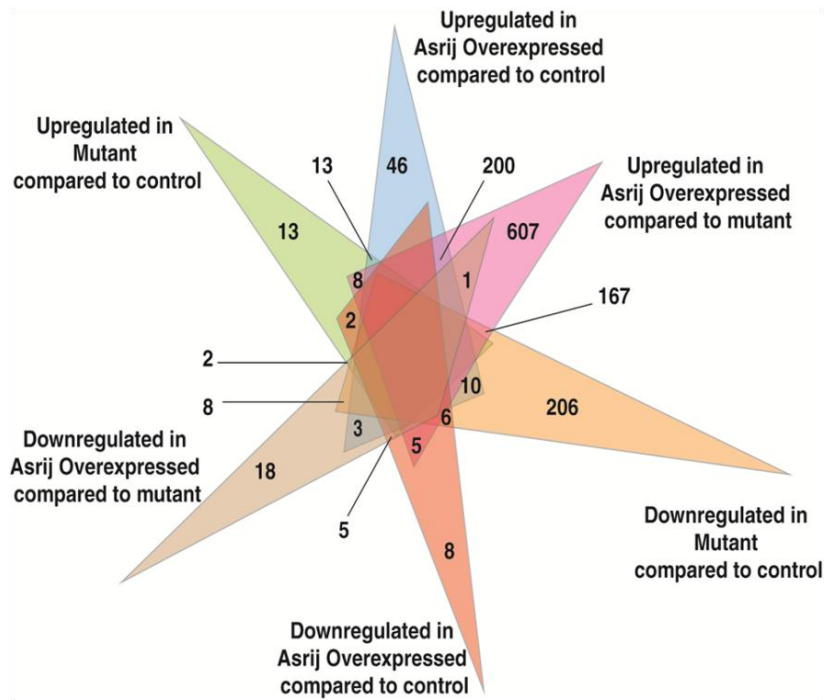

**Figure 2.3:** Venn diagram showing the overlap of differentially expressed proteins in Asrij knockout and overexpression conditions.

The lymph gland proteome identified known proteins involved in *Drosophila* hematopoiesis and immunity. For example, the receptor tyrosine kinase *Pvr*, which shares homology with vertebrate PDGF, plays a significant role in *Drosophila* hematopoiesis (Jung et. al., 2005) and *Turandot-A*, a JAK/STAT-dependent humoral factor which is strongly induced upon by bacterial challenge (Ekengren et. al., 2001). Analysis of the molecular profiling data in Asrij depleted and overexpressed conditions yielded protein clusters that predominantly affect major cellular processes such as endocytosis, oxidative phosphorylation and metabolism.

Recently, endocytosis is being recognized as the crucial mediator and regulator of signalling between the plasma membrane and nucleus (Sigismund et. al., 2012). Proteomics-based approach aided identification of proteins affected by Asrij in the endocytic pathway. Several proteins associated with endosome formation, recycling endosomes, late endosomes and several components of the endosomal sorting complex required for transport (ESCRT)

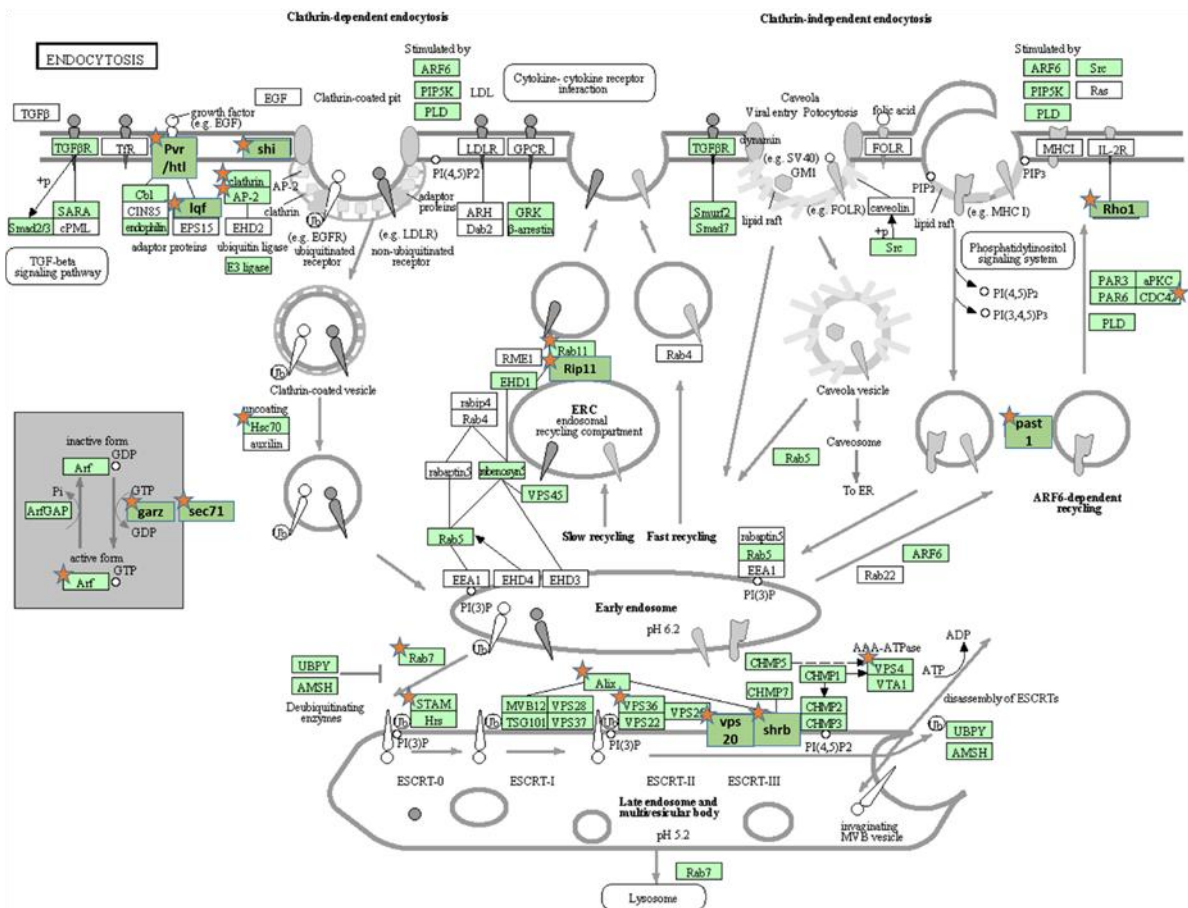

**Figure 2.4:** Differentially expressed proteins (highlighted with red star) of the cellular transport machinery upon Asrij perturbation (*Modified from KEGG pathway database*).

<b>ESCRT machinery</b>	
<b>Complex</b>	<b><i>Drosophila</i> protein name</b>
ESCRT-0	<b><i>STAM</i></b>
	<b><i>Hrs</i></b>
ESCRT-I	<b><i>Vps28</i></b>
	<b><i>Tsg101</i></b>
	<b><i>Vps37</i></b>
ESCRT-II	<b><i>MVB12</i></b>
	<b><i>Vps22</i></b>
	<b><i>Vps25</i></b>
	<b><i>Vps36</i></b>
ESCRT-III	<b><i>Vps2</i></b>
	<b><i>Vps20</i></b>
	<b><i>Vps24</i></b>
	<b><i>Vps32</i></b>

**Table 2.1: Proteins of the ESCRT complex affected upon perturbation of Asrij levels.** List of proteins comprising different ESCRT complexes. Bold and italicised proteins were affected upon perturbation of Asrij levels.

complex were affected on perturbation of Asrij suggesting an essential role for Asrij in cargo sorting (Refer Figure 2.4, Table 2.1).

Modulation of Asrij levels took a dramatic toll on the cell's transport machinery. Expectedly, components of the JAK/STAT pathway showed altered expression in Asrij depleted and overexpressed conditions.

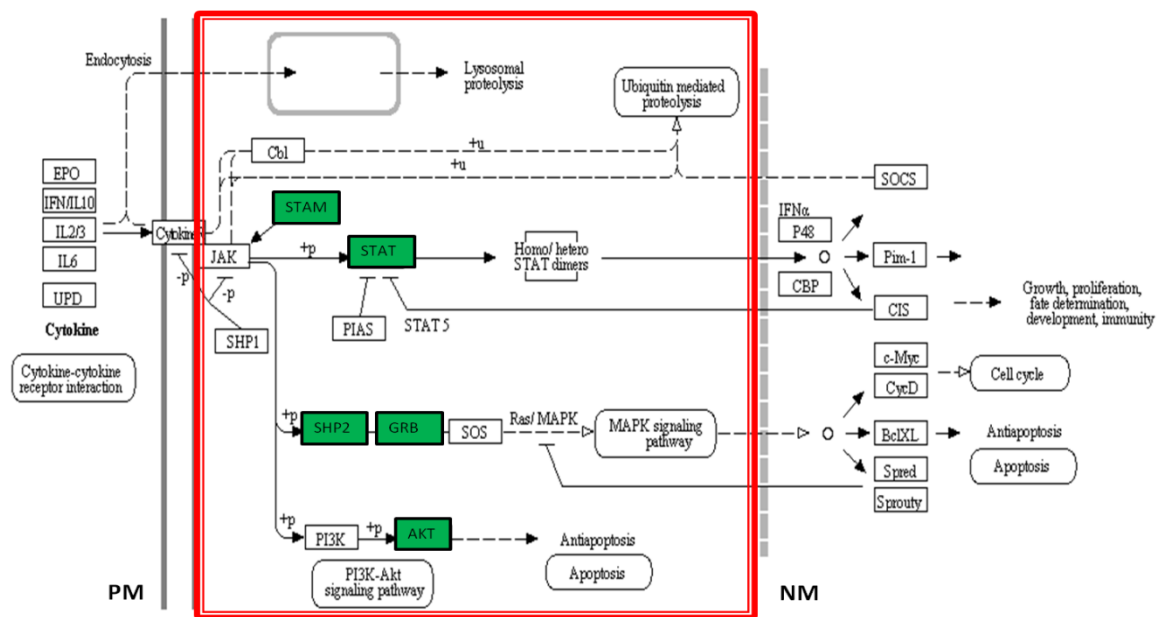

**Figure 2.5:** Differentially expressed proteins (coloured in green) of the JAK/STAT pathway upon Asrij perturbation (Modified from KEGG pathway database). PM and NM refer to the plasma membrane and nuclear membrane.

Previous studies have shown that Asrij depletion affects the activation of STAT3, a key molecule of the JAK/STAT pathway (Sinha et. al., 2013). In addition to STAT92e, the lymph gland proteome revealed other cytosolic molecules affected in the JAK/STAT pathway such as STAM (Signal Transducing Adaptor Molecule), Akt1, SHP2 (a protein tyrosine phosphatase, also called PTPN11) and GRB2 (Growth factor receptor-bound protein 2) which were also affected on perturbation of Asrij (Refer Figure 2.5, Table 2.2).



<b>JAK/STAT Pathway</b>		
<b>Proteins affected</b>	<b>Asrij Mutant</b>	<b>Asrij Over-expression</b>
STAM	0.67	0.93
STAT92e	0.84	1.31
SHP2	0.76	1.10
GRB	0.90	1.28

**Table 2.2:** List of proteins involved in the JAK/STAT pathway that are differentially expressed upon Asrij perturbed conditions. Values below and above 1 represent the down-regulated and up-regulated fold change of proteins in Asrij mutant and Asrij overexpressed conditions, respectively.

Asrij negatively regulates the Notch pathway; loss of Asrij causes a rapid increase in the entrapment of Notch Intracellular Domain (NICD) in Hrs+ sorting endosomes leading to increased crystal cell differentiation (Kulkarni and Khadilkar et. al., 2012). Interestingly, the proteome results provided us with a list of regulators of Notch pathway that were affected on Asrij knockout or overexpression – *shibire*, *liquid facets*, *putzig*, *hephaestus*, *Ras-like protein A*, *actin-related protein 3 (Arp3)*, *endonuclease G inhibitor*, *clathrin heavy chain*, *actin-related protein 2/3 complex subunit 1*, *nucleosome remodelling factor-38*, *deadpan* and *GDP-mannose 4,6-dehydratase* (Refer Table 2.3).



### Notch Pathway

Proteins affected	Asrij Mutant	Asrij Over-expression
shi	0.63	1.39
RpL13A	0.61	1.25
heph	0.81	1.10
Rala	1.06	1.69
Arpc1	0.53	1.26
Arp3	0.85	1.24
dpn	0.91	1.30
VhaAC39-1	0.98	1.82
Chc	0.83	1.28
Nurf-38	0.68	1.20
Gmd	0.89	1.09
Vps36	0.92	1.41
pzg	1.20	1.55
EndoGl	0.69	0.82
Iqf	0.63	0.76

**Table 2.3:** List of proteins involved in the Notch pathway that are differentially expressed upon Asrij perturbed conditions. Values below and above 1 represent the down-regulated and up-regulated fold change of proteins in Asrij mutant and Asrij overexpressed conditions, respectively.

Apart from endocytosis, oxidative phosphorylation machinery was severely affected on modulation of Asrij levels suggesting a novel role for Asrij in this pathway. Oxidative phosphorylation plays a major role in deciding the fate of a hematopoietic stem cell and is carried out by a series of protein complexes namely mitochondrial complex I, complex II, complex III and complex IV (Rafalski et. al., 2012; Shyh et. al., 2013). Modulation of Asrij levels affected several components of the oxidative phosphorylation machinery including various subunits of NADH dehydrogenase, cytochrome c oxidase, v-type ATPase, f-type ATPase and succinate dehydrogenase B (Refer Figure 2.6).

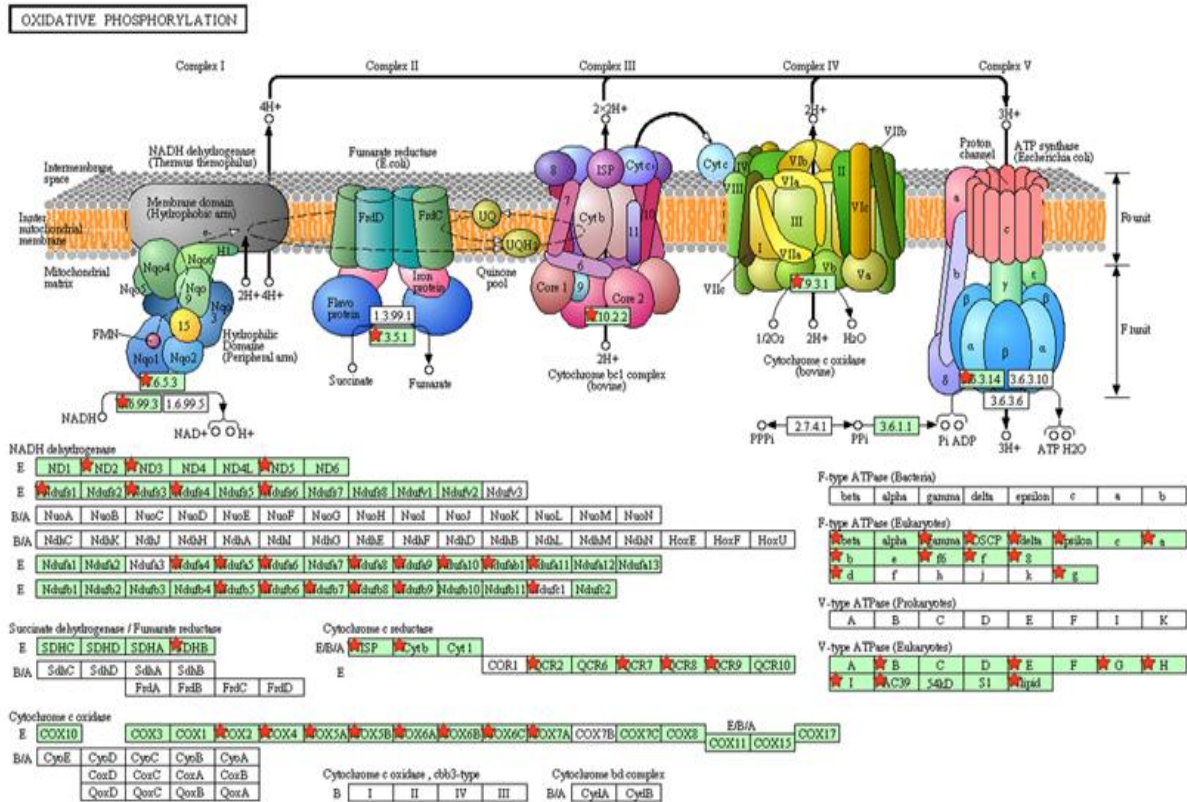

**Figure 2.6:** Differentially expressed proteins (highlighted with red star) of the oxidative phosphorylation pathway upon Asrij perturbation (*Modified from employees.csbsju.edu*).

## 2.4 Discussion

Endosomal trafficking has recently been shown to actively regulate cellular processes including stem cell maintenance and differentiation. Control of signal generation, maintenance, down regulation and attenuation by endosomal proteins is a complex process involving multiple and often transient interactions. Elucidation of mechanisms that operate in endosomal regulation requires identification and analysis of the numerous proteins that facilitate this process *in situ*.

Proteomics of the genetically modified *Drosophila melanogaster* lymph glands presented many novel predictions by implicating new proteins that are regulated by Asrij and pointing to it as a previously unknown hub of signal integration. Of 870 proteins, whose

expression was dependent on Asrij levels, 58 were reciprocally regulated in Asrij depleted and overexpression lymph glands. Knowledge obtained from the lymph gland proteomics highlights that endocytic proteins are multi-faceted. Beyond their contribution to intracellular trafficking, endocytic proteins also play an important role in determining the net output of several other cellular processes such as oxidative phosphorylation and metabolism.

Proteomics of the lymph glands provided us with an extended list of Asrij-regulated proteins that may be involved in *Drosophila* hematopoiesis. Expectedly, components of the JAK-STAT and Notch signalling pathways and a wide array of molecules involved in the endocytic pathway showed altered expression.

The STAM family of proteins are conserved from insects to vertebrates. They associate with the hepatocyte growth factor regulated substrate (Hrs) and bind ubiquitin and ubiquitinated proteins via their ubiquitin interacting motif (UIM) (Muzino et. al., 2003). STAM does not have an established function in hematopoiesis but is known to participate in sorting of cargo proteins for trafficking to the lysosomes. Asrij knockout causes downregulated STAM levels as inferred from the *Drosophila* lymph gland proteome.

The function of Akt and its role in normal and malignant hematopoiesis is well established (Warr and Passegue, 2011). Constitutive activation of this signalling module induces several haematological malignancies and hence a variety of pharmacological inhibitors are directed against Akt (Khan et. al., 2013).

Shp2 is a Src-homology 2 domain bearing ubiquitous tyrosine protein phosphatase associated with important biological functions such as ERK activation for cell growth and differentiation; mitotic cycle and has also been implicated in oncogenesis (Yu et. al., 2014). Suppression of SHP2 function has been shown to facilitate progression of myeloproliferative neoplasm (Matsuda et. al., 2014).

GRB2 is an adaptor protein involved in various cellular processes and its targeted gene disruption in mouse is early embryonic lethal (Cully et. al., 2004; Giubellino et. al., 2008). The role of GRB2 in hematopoiesis is yet to be elucidated but previous studies have shown that Gads (Grb2-related adaptor downstream of Shc) is required for progression of Bcr-Abl mediated lymphoid leukemia (Gillis et. al., 2013).

For the purpose of validation of the results obtained from proteomics and to test the function of these proteins in hematopoiesis, we need to express several relevant RNAi lines under the control of *e33c-Gal4* driver and correlate the effect of the knockdown with the mass spectrometry data obtained. This is the first report of an in-depth analysis and validation of the *Drosophila* lymph gland proteome *in vivo*. Given the high conservation of molecules and signalling pathways between *Drosophila* and vertebrate hematopoiesis, our study gives novel insight into conserved mechanisms of hematopoiesis and will also be applicable to understanding stem cell regulation. In future, the lymph gland proteome could be used as a reference for analysis of protein alterations associated with various haematological malignancies.

## **Chapter 3: Functional role of Asrij in mouse hematopoiesis**

### **3.1 Introduction**

Hematopoiesis is initiated by a small population of stem cells which undergo several rounds of proliferation and sequential differentiation to give rise to terminally differentiated blood cells (Merchan et. al., 2011). The hematopoietic stem cell niche in vertebrates is known to play an important role in the maintenance and differentiation of blood cell precursors. Several factors expressed in defined microenvironments of the bone marrow regulate HSC behaviour (Smith et. al., 2013). The bone marrow consists of two distinct compartments – the stromal cells acting as the niche and the HSCs. Stromal cells provide structural and physiological support to the HSCs and also play an important role in regulating their ordered proliferation and differentiation (Krebsbach et. al., 1999; Barros et. al., 2010). Disruption of the niche or alterations in the balance between stemness and differentiation lead to aberrant hematopoiesis and often result in bone marrow failure or leukemias such as myeloproliferative neoplasms (MPNs) (Ackigoz et. al., 2008; Yalcin et. al., 2010).

MPNs are of different kinds such as polycythemia vera (overproduction of RBCs), essential thrombocythemia (overproduction of platelets), chronic myelomonocytic leukemia (overproduction of WBCs), chronic neutrophilic leukemia (overproduction of neutrophils), chronic eosinophilic leukemia (overproduction of eosinophils) and idiopathic myelofibrosis (bone marrow fibrosis) (Tefferi and Vardiman, 2008).

Aberrations in hematopoiesis are well studied and easily assessed in the peripheral blood and bone marrow. To understand the endocytic regulation of hematopoiesis, we focussed our analysis on a blood-specific endosomal protein, Asrij, which is a member of the OCIA (Ovarian Carcinoma Immunoreactive Antigen) domain family. Asrij was first identified as a

gene expressed in mouse embryonic stem cells and the developing blood vasculature (Mukhopadhyay et. al., 2003). It is a key player in *Drosophila* hematopoiesis where it is essential for niche maintenance and is known to negatively regulate hemocyte differentiation. Previous studies have shown that *Asrij* is required for maintenance of pluripotency in mouse embryonic stem cells (mESCs). Interestingly, mouse *Asrij* and *Drosophila* *Asrij* are homologs and mouse *Asrij* can maintain the stem cell state in *Drosophila* owing to the conserved OCIA domain in the *Asrij* N-terminal (Sinha et. al., 2013).

Hence, we decided to test whether the function of *Asrij* is conserved across model systems and extended our analysis to the vertebrate model. This chapter describes the validation and phenotypic analysis of the available *asrij* null mice that had been generated by targeted gene disruption and analysis of the hematopoietic compartments of the mutant mice.

## **3.2 Materials and Methods**

### **3.2.1 Generation of *asrij*<sup>fl/fl</sup>;Cre mice**

*asrij*<sup>fl/fl</sup> mice bearing *loxP* sites on either side of exon 6 of *asrij* (generated earlier in the laboratory in collaboration with the RIKEN Centre for Developmental Biology, Kobe, Japan) were mated with *CMV-Cre* mice to generate *asrij*<sup>fl/fl</sup>;Cre mice which were genotyped and available for my study (Refer Figure 3.1). Mice were maintained in accordance with Institutional Animal Ethics Committee (IAEC) guidelines.

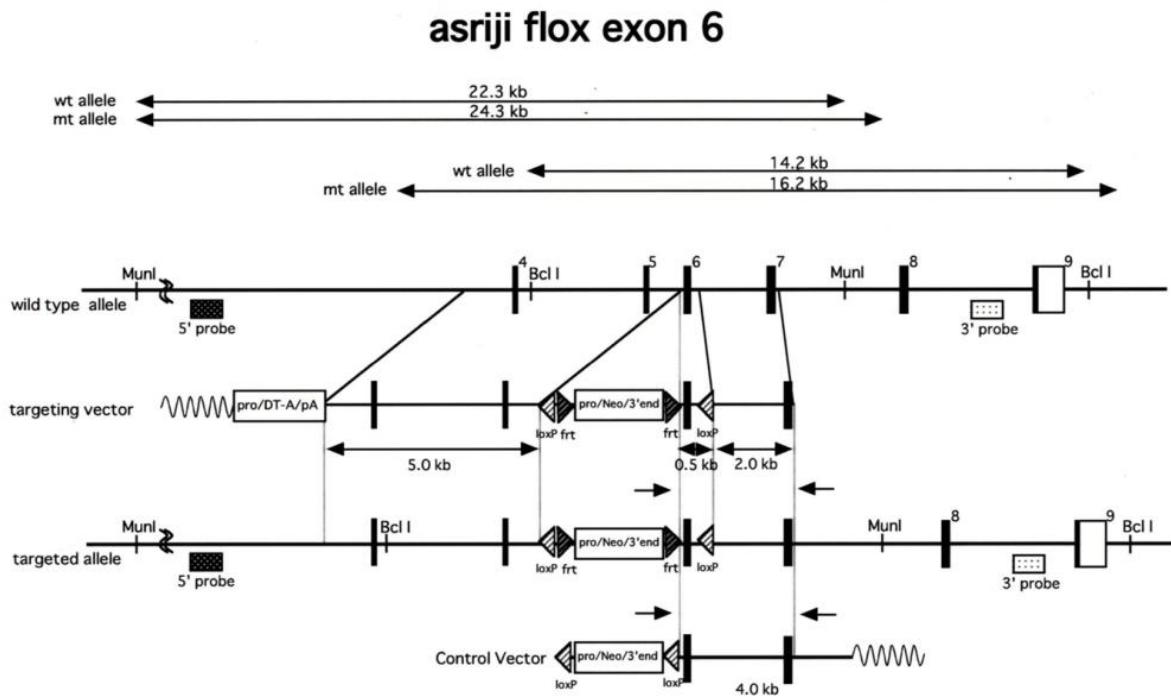

**Figure 3.1:** Schematic representing *asriji* exon 6 gene targeting.

### 3.2.2 Validation of *asriji<sup>fl/fl</sup>;Cre* mice

The specific genetic identification of mice was done using Polymerase Chain Reaction (PCR). Genomic DNA was extracted from tail clippings of mice (Catalogue No.: G1N70-1KT, GenElute Mammalian Genomic DNA MiniPrep Kit, Sigma) and was analysed by PCR. Primers used for genotyping were: 5'-GGAGAATTGCGGCGCTCTTCTCC-3' and 5'-CCATCCATCCCTCTCCACTGG-3'; to amplify wild type locus (608 bp) and floxed locus (681 bp), and 5'-ATGAAGCAGTGTCTTGGGATTGC-3' and 5'-CCATCCATCCCTCTCCACTGG-3'; to identify the excised copy (535 bp) (Refer Figure 3.2).

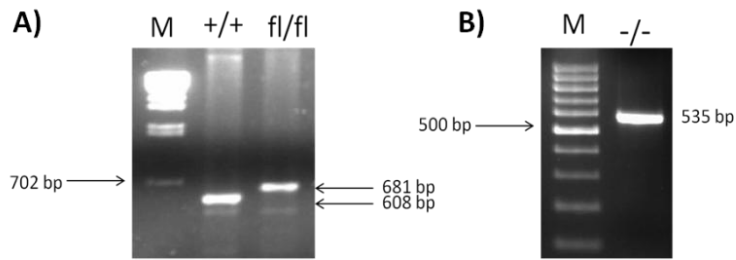

**Figure 3.2: Genotyping by PCR** A) Control and floxed Asrij mice. B) Asrij null mice.

### 3.2.3 Western Blotting

Mouse tissues (heart, kidney, liver and spleen) were homogenized in ice-cold lysis buffer consisting of 1% Nonidet- P-40, 150mM NaCl, 50mM Tris/HCl, pH 7.5 and PI Cocktail (Catalogue No. P8340-5ml, Protease Inhibitor Cocktail, SIGMA), incubated on ice for 30 minutes with intermittent vortexing and then lysates were cleared by centrifugation at 13,000 rpm for 10 minutes. The supernatant was collected into fresh vials and Bradford's Assay (Catalogue Number: 500-0006, Protein Assay Dye Reagent Concentrate, 450 ml, Bio-Rad) was done to estimate protein concentration of the lysates, before proceeding to Western Blotting.

### 3.2.4 Antibodies used for Western Blotting

Antibodies and dilutions used for Western Blotting analysis were directed against- Asrij (Catalogue No.: ab91574, Rabbit polyclonal antibody to OCIAD1/Asrij, Abcam, dilution 1:1000). Lysates were normalized with respect to GAPDH (Catalogue No.: G9545, Rabbit polyclonal GAPDH antibody, SIGMA, dilution 1:4000) expression levels. Secondary antibody used was HRP-conjugated (Catalogue No.: 621140380011730, Goat anti-rabbit IgG-HRP antibody, GeNei, dilution 1:2000).

### 3.2.5 Immunostaining of bone marrow cells

Mouse bone marrow was flushed using sterile PBS from femur and tibia and single cell suspension obtained was passed through a 70  $\mu$ m cell strainer. Filtered bone marrow cell suspension was centrifuged at 1000 g for 2 minutes and the pellet obtained was resuspended in



PBS. Cells were fixed in 4% paraformaldehyde solution (Merck, Millipore, USA) for 20 minutes at room temperature. After fixation, cells were washed with PBS and permeabilized with 0.1% Triton X-100 (SIGMA, Chemical Co., USA) in PBS for 20 minutes at room temperature. Cells were blocked with 3% FBS (GIBCO, Invitrogen, Carlsband, USA) for 1 hour at room temperature and then incubated with primary antibodies overnight at 4 °C, followed by two washes with PBS. 1:400 dilution of appropriate secondary antibody conjugated either to Alexa 488 or Alexa 568 (Molecular Probes, Carlsbad, CA) in PBS was added and incubated for 1 hour at room temperature. Cells were then washed twice with PBS and mounted in Anti-fade containing DAPI (Invitrogen, Carlsbad, USA) for imaging.

### ***3.2.6 Antibodies used for immunostaining***

Antibodies, namely, rabbit anti-OCIAD1 antibody (Catalogue No.: ab91574, Abcam) in the dilution 1:100 and mouse anti-CD45 antibody (Catalogue No: 550566, BD Pharmingen) in the dilution 1:40. Secondary antibodies such as Alexa Fluor 488 and Alexa Fluor 568 were used in dilution 1:400 (Molecular Probes, Inc.).

### ***3.2.7 Complete blood cell counts***

Mouse peripheral blood was collected from punctured retro-orbital venous plexus into vials containing 2% EDTA (anticoagulant) solution (Catalogue No.: TC038, Himedia Laboratories). Complete blood cell counts were determined using an automated hematologic analyzer (Sysmex XP-100).

### ***3.2.8 Flow cytometry analysis of bone marrow compartment***

Mouse bone marrow was flushed using sterile PBS from femur and tibia and single cell suspension was obtained by passing it through a 70 µm cell strainer to avoid clumps. Filtered bone marrow cell suspension was centrifuged at 1000 X g for 2 minutes and resuspended in 1 ml of sterile PBS. Cell viability was assessed by 7-amino-actinomycin D (7-AAD) dye efflux

activity. Fluorescently conjugated antibodies used for characterization of HSCs and HPCs were lineage cocktail [CD3-T cell marker, CD45R(B220)-B cell marker, Ly6C & Ly6G(GR1)-Granulocyte marker, CD11b(Mac1)-Macrophage marker and TER 119- RBC marker], PE-Cy7-labelled Sca-1, PE-labelled c-Kit (CD117) and FITC-labelled CD34. (Catalogue No.: BD 560492, Mouse Hematopoietic Stem Cell Isolation Kit, BD Biosciences). After staining, HSCs and HPCs were analyzed by flow cytometry (FACS Aria II, BD Biosciences). These experiments were performed with the help of B.V.Anudeep, Ronak Shetty, W. Praveen and Deeti Shetty.

### **3.2.9 Imaging and analysis**

Images of stained bone marrow cells were captured using Zeiss LSM510meta confocal microscope and were analyzed using Zeiss LSM Image examiner software (Version 4.2.0.0).

### **3.2.10 Statistical analysis and quantification**

Statistical comparison of complete blood cell counts of  $asrij^{fl/fl}$  and  $asrij^{fl/fl};Cre$  mice of different age groups was done using Single Factor ANOVA. Probability of  $p < 0.05$  was considered statistically significant for the same.

## **3.3 Results**

### **3.3.1 $asrij^{fl/fl};Cre$ mice are viable**

$asrij^{fl/fl};Cre$  mice were viable and fertile and showed no obvious physiological defects on comparison with their littermate controls.  $Asrij$  deficiency did not affect the lifespan of the mice. Demise of 12 months or older  $asrij^{fl/fl};Cre$  mice was characterized by precipitous weight loss but a definitive cause of death was not identified.

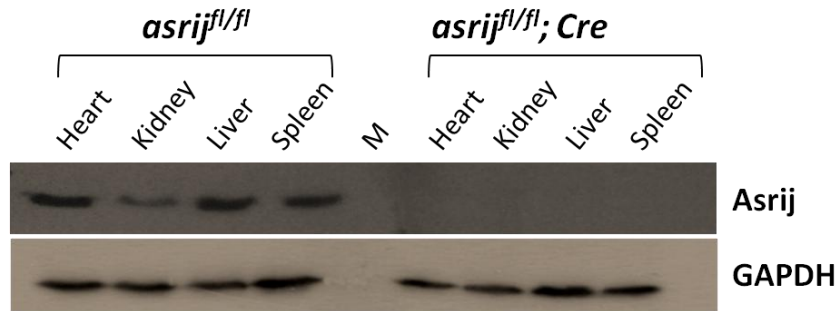
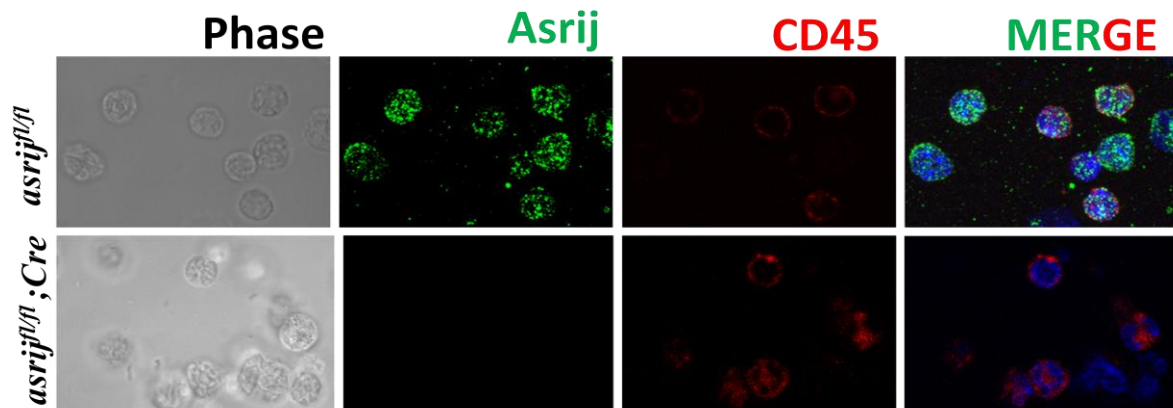

**Figure 3.3: Western Blotting of mouse tissue lysates for confirmation of genotype.** Analysis of *asrij<sup>fl/fl</sup>* and *asrij<sup>fl/fl</sup>;Cre* mouse tissues showed complete knockout of Asrij. M refers to Prestained Protein Marker.

All experiments were performed on *asrij<sup>fl/fl</sup>* and *asrij<sup>fl/fl</sup>;Cre* mice between ages of 1 to 12 months.

### 3.3.2 Expression analysis of Asrij in mouse bone marrow cells

In *Drosophila*, Asrij is a pan hemocyte marker. To check whether Asrij is expressed in mouse HSCs, we performed immunostaining of bone marrow cells. We stained the cells with Asrij and CD45, a known hematopoietic lineage-restricted antigen (Ogata et. al., 2005). We found that Asrij is present in most of the CD45<sup>+</sup> cells showing punctate staining in the cytoplasm of cells. We could not detect any Asrij staining in the cells of *asrij<sup>fl/fl</sup>;Cre* mice which confirmed that Asrij was not expressed in their bone marrow hematopoietic compartment (Refer Figure 3.4).



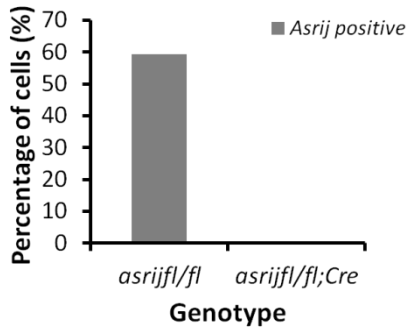
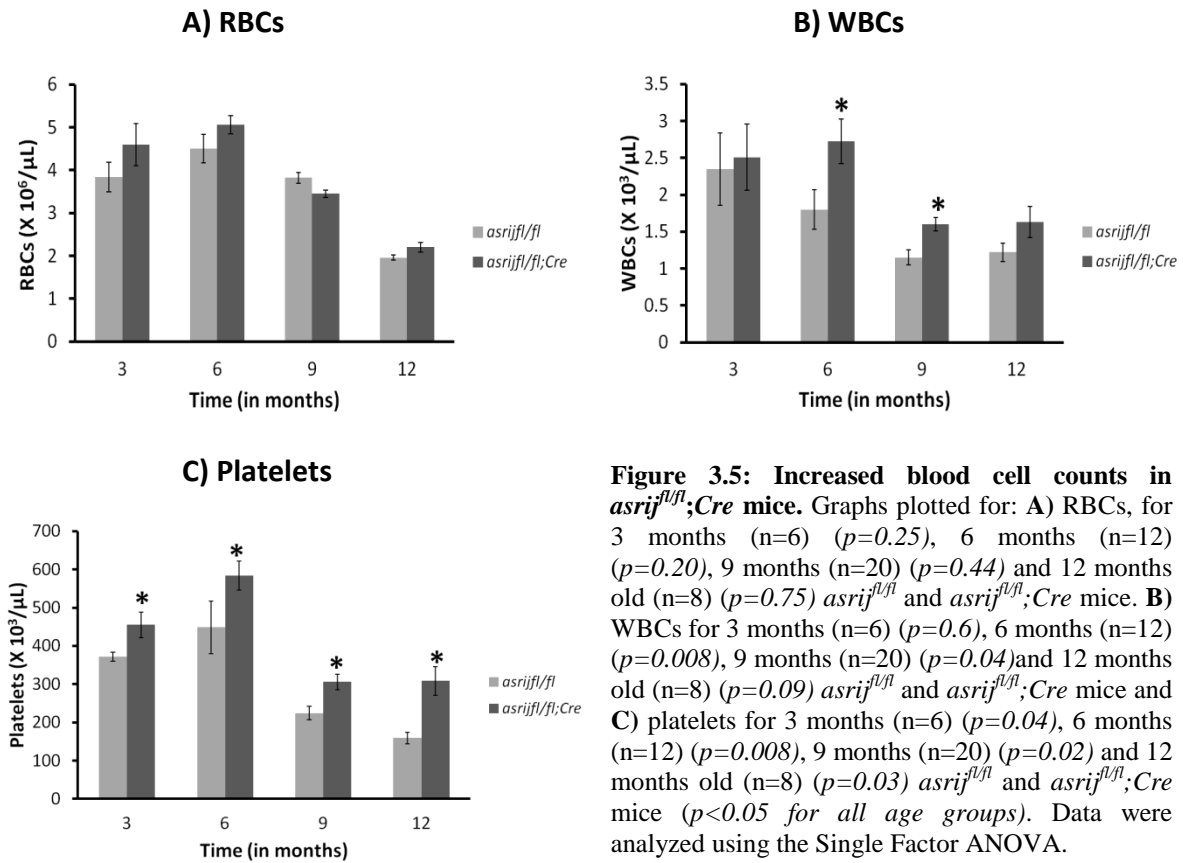

**Figure 3.4: Asrij is expressed in the hematopoietic cells of bone marrow.** A,B) Bone marrow cells isolated from *asrij<sup>fl/fl</sup>* and *asrij<sup>fl/fl</sup>;Cre* mice stained for expression of Asrij (green) and CD45 (red), a pan-hematopoietic marker (n=2). Images taken at 40X and 100X magnifications for A) and B) respectively (Imaging courtesy: Simi Muraleedharan). C) Graph representing percentage of cells expressing Asrij in the bone marrow of control and mutant mice.

Assessment of blood and bone marrow is a routine procedure in the investigation of hematological disorders. Hence, we evaluated peripheral blood counts and analyzed the bone marrow hematopoietic compartment of *asrij<sup>fl/fl</sup>;Cre* mice, to check for hematological defects, if any.

### 3.3.3 Steady state of hematopoiesis is affected in *asrij<sup>fl/fl</sup>;Cre* mice

Analysis of peripheral blood (PB) counts in 3 months old *asrij<sup>fl/fl</sup>;Cre* mice revealed increased counts of RBCs and WBCs ( $p > 0.05$  for both) and significantly increased platelets ( $p < 0.05$ ) relative to controls. WBCs and platelets were significantly high ( $p < 0.05$ ) in 6 months and 9 months old *asrij<sup>fl/fl</sup>;Cre* mice. The increase in platelets was sustained in 12 months old *asrij<sup>fl/fl</sup>;Cre* mice ( $p < 0.05$ ). We did not observe any difference in the RBC counts of both the genotypes (Refer Figure 3.5).



**Figure 3.5: Increased blood cell counts in *asrij<sup>fl/fl</sup>;Cre* mice.** Graphs plotted for: **A)** RBCs, for 3 months (n=6) ( $p=0.25$ ), 6 months (n=12) ( $p=0.20$ ), 9 months (n=20) ( $p=0.44$ ) and 12 months old (n=8) ( $p=0.75$ ) *asrij<sup>fl/fl</sup>* and *asrij<sup>fl/fl</sup>;Cre* mice. **B)** WBCs for 3 months (n=6) ( $p=0.6$ ), 6 months (n=12) ( $p=0.008$ ), 9 months (n=20) ( $p=0.04$ ) and 12 months old (n=8) ( $p=0.09$ ) *asrij<sup>fl/fl</sup>* and *asrij<sup>fl/fl</sup>;Cre* mice and **C)** platelets for 3 months (n=6) ( $p=0.04$ ), 6 months (n=12) ( $p=0.008$ ), 9 months (n=20) ( $p=0.02$ ) and 12 months old (n=8) ( $p=0.03$ ) *asrij<sup>fl/fl</sup>* and *asrij<sup>fl/fl</sup>;Cre* mice ( $p<0.05$  for all age groups). Data were analyzed using the Single Factor ANOVA.

The table below represents the peripheral blood hemogram of *asrij<sup>fl/fl</sup>* and *asrij<sup>fl/fl</sup>;Cre* mice:

**Table 1. Complete blood counts of *asrij<sup>fl/fl</sup>* and *asrij<sup>fl/fl</sup>;Cre* mice**

Parameter	<i>asrij<sup>fl/fl</sup></i>	<i>asrij<sup>fl/fl</sup>;Cre</i>	<i>p</i> -value
Red Blood Cells ( X 10 <sup>6</sup> /uL)	4.5 ± 0.33	5.06 ± 0.21	NS
White Blood Cells ( X 10 <sup>3</sup> /uL)	1.875 ± 0.27	2.725 ± 0.308	< 0.05
Platelets ( X 10 <sup>3</sup> /uL)	449 ± 68	584 ± 38	< 0.05
Hemoglobin (g/dL)	7.22 ± 0.56	7.54 ± 0.32	NS
Hematocrit (%)	22.57 ± 1.81	24.57 ± 1.12	NS
MCV (fL)	50.02 ± 0.48	48.45 ± 0.48	< 0.05
MCH (pg)	16.175 ± 0.17	14.891 ± 0.12	NS
MCHC (g/dL)	32.05 ± 0.58	30.73 ± 0.15	< 0.05
Lymphocytes (%)	90.25 ± 0.53	82.025 ± 1.97	NS
Neutrophils (%)	9.75 ± 0.5	18.05 ± 2.0	NS

**Table 3.1: Peripheral blood hemogram of 6 months old *asrij<sup>fl/fl</sup>* and *asrij<sup>fl/fl</sup>;Cre* mice.** Results are expressed as mean ± SEM (n=14). MCV, MCH and MCHC indicate mean corpuscular volume, mean corpuscular hemoglobin and mean corpuscular hemoglobin concentration respectively. NS indicates not significant.

### 3.3.4 Increase in the HSC population in *asrij<sup>fl/fl</sup>;Cre* mice

To investigate the potential role of *Asrij* in regulating primitive hematopoietic stem cell function, we performed bone marrow flow cytometry analysis that helped us to characterize the immunophenotypic profile of various sub-populations of HSCs. Flow cytometry analysis was performed on single cell suspensions of bone marrow isolated from *asrij<sup>fl/fl</sup>* and *asrij<sup>fl/fl</sup>;Cre* mice of age, 2 months (n=4), 4 months (n=7), 6 months (n=4), 8 months (n=2) and 12 months (n=5). Fluorescence-activated cell sorting (FACS) plots were gated on the L<sup>S</sup>K<sup>+</sup> (LSK) subpopulation, which was sub-classified for the expression of CD34 to give the percentages of LT-HSCs (CD34<sup>+</sup>) and ST-HSCs (CD34<sup>-</sup>). Compared to controls, *asrij<sup>fl/fl</sup>;Cre* mice showed an increase in LT-HSCs at 6 months and 8 months of age and this increase was significantly exacerbated in 12 months old mice ( $p < 0.05$ ).

We did not observe any change in the number of ST-HSCs in 3 months and 6 months old *asrij<sup>fl/fl</sup>;Cre* mice but there was an increase at 8 months of age and the increase was significant at 12 months of age ( $p < 0.05$ ) (Refer Figure 3.6). These data indicate an overall increase in the absolute number of HSCs in *asrij<sup>fl/fl</sup>;Cre* mice.

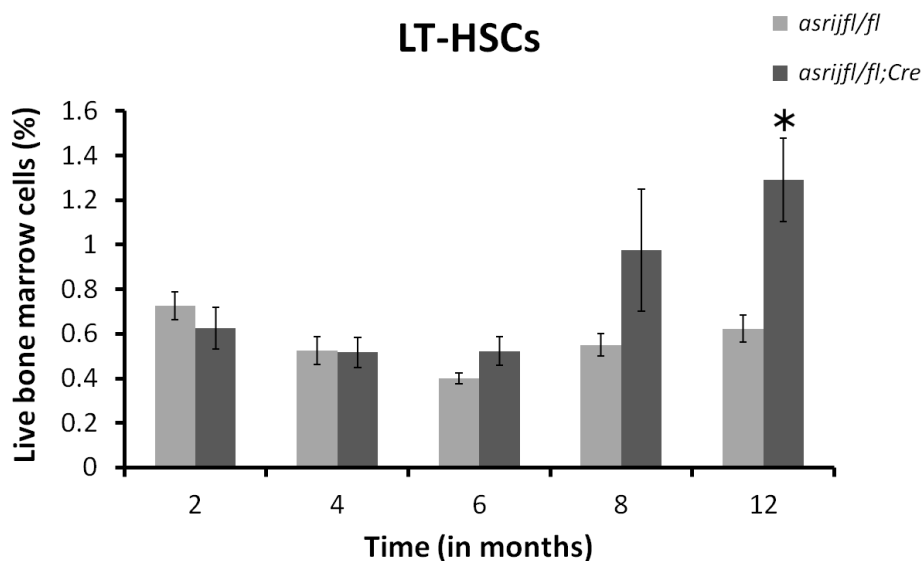

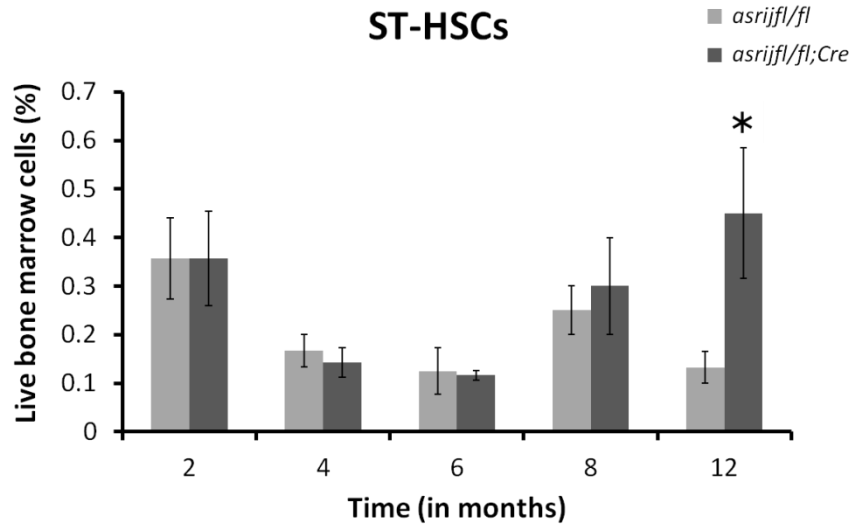

**Figure 3.6: Flow cytometry analysis revealed an increase in the HSC population in *asrij*<sup>fl/fl</sup>;*Cre* mice.** Analysis was done for LT-HSC counts for 2 months (n=4) ( $p=0.41$ ), 4 months (n=7) ( $p=0.93$ ), 6 months (n=4) ( $p=0.12$ ), 8 months (n=2) and 12 months (n=5) ( $p=0.01$ ) aged *asrij*<sup>fl/fl</sup> and *asrij*<sup>fl/fl</sup>;*Cre* mice and ST-HSC counts for 2 months (n=4) ( $p=0.9$ ), 4 months (n=7) ( $p=0.60$ ), 6 months (n=4) ( $p=0.84$ ), 8 months (n=2) and 12 months (n=5) ( $p=0.02$ ) aged *asrij*<sup>fl/fl</sup> and *asrij*<sup>fl/fl</sup>;*Cre* mice. LT-HSCs and ST-HSCs were significantly high in 12 months old *asrij*<sup>fl/fl</sup>;*Cre* mice. Data were analyzed using the Single Factor ANOVA.

### 3.4 Discussion

For analysis, we used *asrij*<sup>fl/fl</sup>;*Cre* mice generated previously by the targeted deletion of exon 6 via Cre-LoxP recombination and that completely lacked Asrij protein. Genetic validation of the mutant mice was done by genotyping, employing techniques such as PCR and Western Blotting. *Asrij* knockout mice were viable and fertile and this suggests that *Asrij* is probably dispensable for embryonic hematopoiesis.

Several studies have reported that down-regulation of *asrij/ociad1* is associated with various leukemias (Shen et. al., 2002; Shen et. al., 2003; Kano et. al., 2007). This supports a regulatory role for *Asrij*. The results presented in this chapter provide the first experimental demonstration of perturbed hematopoiesis in *asrij*<sup>fl/fl</sup>;*Cre* mice. We report that the endocytic protein *Asrij* has a key role in controlling homeostasis of the hematopoietic stem cell compartment. Loss of *Asrij* affects steady state hematopoiesis in mice leading to significantly increased numbers of circulating blood cells such as WBCs and platelets. Defects in steady

state hematopoiesis often imply functional impairment of hematopoietic stem cells and progenitor cells in the bone marrow compartment. Expectedly, bone marrow flow cytometry analysis of *asrij<sup>fl/fl</sup>;Cre* mice revealed severely disrupted homeostasis as was reflected by the marked increase in LT-HSCs and ST-HSCs.

In *Drosophila*, *Asrij* is required for niche maintenance and is known to negatively regulate differentiation (Kulkarni and Khadilkar et. al., 2011). As mentioned earlier, in vertebrates, bone marrow stromal cells secrete factors required for proliferation and maintenance of HSCs. Deficiency of *Asrij* in the bone marrow niche probably leads to overproliferation of HSCs, suggesting that *Asrij* is required for proper functioning of the bone marrow niche and it is a negative regulator of factors that promote proliferation. The increased population of HSCs in *asrij<sup>fl/fl</sup>;Cre* mice probably leads to increased counts of differentiated blood cells (Refer Figure 3.7).

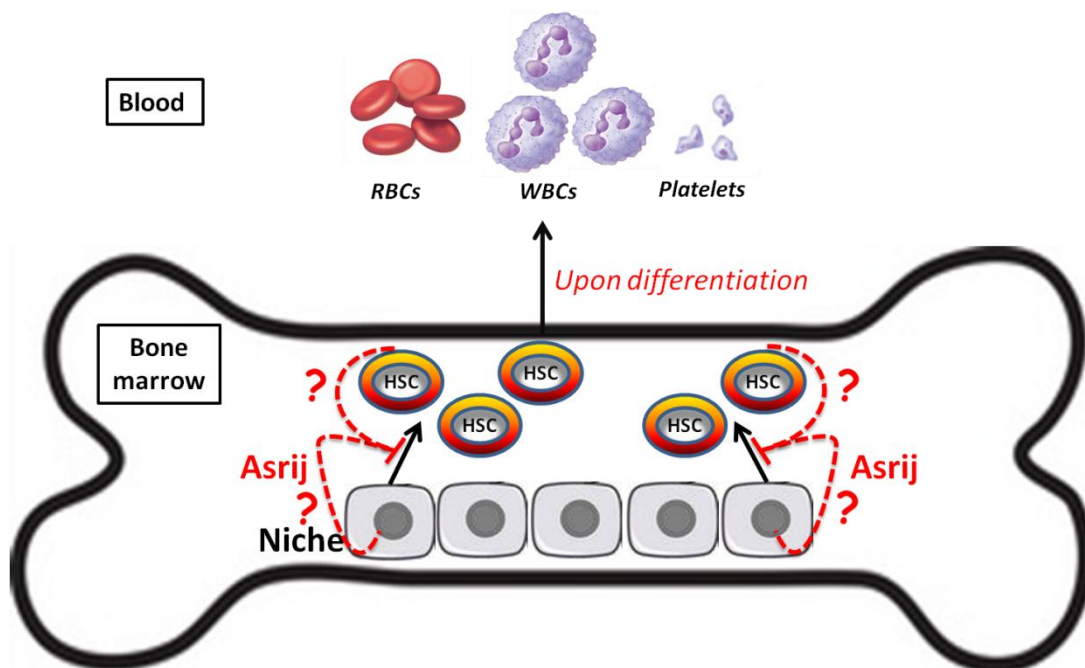

**Figure 3.7: *Asrij* negatively regulates proliferation and differentiation of bone marrow HSCs.** The bone marrow niche consists of a heterogeneous population of cells that govern HSC maintenance and proliferation (represented by solid black arrows). *Asrij* functions to maintain the balance between stemness and differentiation in the bone marrow niche. *Asrij* acts from the niche or endogenously from the HSCs (dashed red arrows); and its deficiency leads to increased proliferation of the HSCs. Thus, *Asrij* acts as a negative regulator (represented by dashed green arrows) of HSC proliferation and maintains blood cell homeostasis.



Thus, in agreement with our previous reports of aberrant hematopoiesis in *Drosophila asrij* loss-of-function mutants, *asrij<sup>fl/fl</sup>;Cre* mice showed increased stem cell numbers and significantly increased WBC and platelet counts, indicating that the mutant phenotype is caused by a perturbation in the conserved gene function. Asrij is a key regulator of hematopoietic stem cell fate as its deregulation contributes to hematological tumor progression. Taken together, these results suggest that deficiency of Asrij induces the uncontrolled proliferation of hematopoietic stem cells and initiates a myeloproliferative disorder in mice. Future investigation of mice depleted of Asrij only in the hematopoietic lineage mice will help provide a better understanding of the role of this endocytic protein in the conserved mechanisms of blood cell specification and differentiation.

## **Chapter 4: Role of Asrij in regulating signalling pathways that control mouse hematopoiesis**

### **4.1 Introduction**

Many novel endocytic players specific to cell type and developmental time have been discovered (Fisher et. al., 2006). By virtue of their cellular location, endocytic molecules are capable of local and rapid modulation of signalling components (Sorkin and Zastrow, 2009). Hematopoiesis, the net biological output of several pathways, relies on cellular signalling and traffic. Several evolutionary conserved pathways such as Wnt, Notch, TGF- $\beta$  and Hedgehog regulate HSC fate (reviewed in Luis et. al., 2012). Impairment of these signalling pathways leads to induction of hematological malignancies (Warr and Passegue, 2011).

For understanding the endocytic regulation of mouse hematopoiesis, we embarked upon a study to analyze the different signalling pathways that are regulated by mouse Asrij. Endocytosis plays an important role in the activation of the Notch pathway (Vaccari et. al., 2008; Fortini et. al., 2009). Asrij controls Notch internalization dynamics and also promotes STAT3 phosphorylation. Besides, Asrij depleted *Drosophila* lymph glands show accumulation of ubiquitin moieties, indicating a defect in the cargo-sorting machinery. These results suggest that Asrij acts at multiple locations along the endocytic route.

Endosomal proteins have been shown to act as scaffolds or adaptors and it is likely that they facilitate cross talk among various signalling components, activating or inhibiting signalling pathways in a context-dependent manner. For example, the different subunits of the COP9 signalosome modulate signalling pathways such as Notch pathway and TGF- $\beta$  pathway, bringing about their activation or inhibition (Oron et. al., 2002; Wei et. al., 2008). Thus, signalling stations which modulate different signalling pathways exist and these play an

important role in deciding the net biological output. Asrij could be a part of a signalosome complex regulating signalling pathways required for maintenance of stemness.

The unique expression and sub-cellular localization of Asrij provides an opportunity to study the role of endocytic mechanisms in mouse hematopoiesis. As mentioned earlier, upon differentiation, expression of Asrij is restricted to blood and cardiovascular lineages. We chose to analyze the status of different signalling pathways that play a conserved role in hematopoiesis using vascularised tissues such as heart, kidney, liver and spleen. Another advantage was, from one tissue several immunoblotting analyses could be performed. We performed an age-dependent analysis using 2 months old mutant mice where we did not observe any difference in the blood cell counts or stem cell counts; using 6 months old mutant mice, where only blood cell counts were high; and the 12 months old mutant mice, where both blood cell counts and stem cell counts were high. Thus, using Asrij knockout mice, our aim was to elucidate the role of Asrij in maintenance of signalling pathways.

## ***4.2 Materials and Methods***

### ***4.2.1 Immunostaining of bone marrow cells***

Immunostaining of bone marrow cells was performed as described previously in section 3.2.5.

### ***4.2.2 Western Blotting analysis***

Western Blotting analysis of tissues was done as described previously in **3.2.3**. Antibodies and dilutions used for Western Blotting analysis were directed against:

<b>Protein</b>	<b>Name of the antibody</b>	<b>Company and catalog number</b>	<b>Dilution</b>
Asrij	Rabbit polyclonal antibody to OCIAD1	Abcam; ab91574	1:1000
Notch Intracellular domain	Rabbit monoclonal antibody to Cleaved Notch 1 (Val 1744)	CST; D3B8	1:1000
Ubiquitin	Rabbit polyclonal antibody to ubiquitin	Abcam; ab19247	1:1000
COPS5	Rabbit polyclonal antibody to COPS5	CST; 6895	1:1000
COPS6	Mouse monoclonal antibody to COPS6	Santa Cruz; sc-393023	1:200
COPS8	Goat polyclonal antibody to COPS8	Santa Cruz; sc-47976	1:200
Akt	Rabbit monoclonal antibody to Akt	Cell Signalling Technologies; 4691S	1:1000
Phospho-Akt	Rabbit monoclonal antibody to phospho-Akt (Ser473)	Cell Signalling Technologies; 4060S	1:1000
STAT3	Mouse monoclonal antibody to STAT3	Cell Signalling Technologies; 9139S	1:1000
Phospho-STAT3	Rabbit monoclonal antibody to phospho-STAT3	Cell Signalling Technologies; 9145S	1:1000

**Table 3.1:** List of primary antibodies and their dilutions used for various Western Blottings.

Lysates were normalized with respect to GAPDH (Rabbit polyclonal GAPDH antibody, SIGMA, Catalogue No.: G9545, dilution 1:4000) expression levels. Secondary antibody used was HRP-conjugated (Goat anti-rabbit IgG-HRP antibody, 1ml, GeNei, Catalogue No.: 621140380011730, dilution 1:2000) and blots were developed using ECL chemiluminescence kit (Thermo Scientific, Rockford, IL, USA).

#### **4.2.3 Imaging and analysis**

Images of stained bone marrow cells were captured using Zeiss LSM510meta confocal microscope and were analyzed using Zeiss LSM Image examiner software (Version 4.2.0.0).

#### **4.2.4 Statistical analyses**

Radiographs obtained from different Western Blotting experiments were processed using ImageJ (version 1.4.3.67) and graphs were plotted using Microsoft Excel.

## 4.3 Results

### 4.3.1 *Asrij* regulates *STAT3* activation in mice

Reporter assays using *Drosophila* *Asrij* mutants showed that *Asrij* plays a dose-dependent role in the activation of the JAK-STAT pathway. In addition, functional complementation studies revealed that mouse *Asrij* could rescue the increased differentiation phenotype in *Drosophila* *Asrij* null mutants to wild-type, indicating that *Drosophila* *Asrij* and mouse *Asrij* are true homologs. Also, in mouse ESCs, *Asrij* was found to interact with STAT3 on Rab5 positive endosomes (Sinha et. al., 2013). Thus, *Asrij* is a positive regulator of the JAK/STAT pathway in *Drosophila* and mammals.

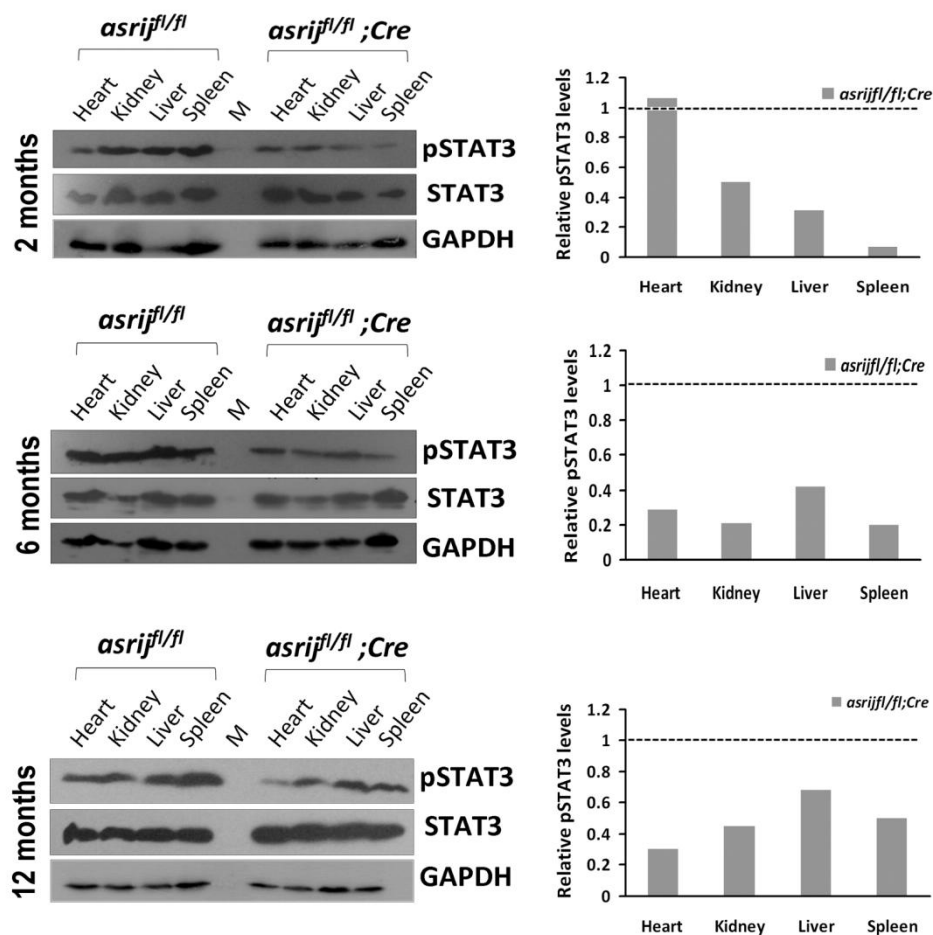

**Figure 4.1: *Asrij* positively regulates the JAK/STAT pathway in mice.** Western Blotting performed across different ages of mice, 2 months (n=2), 6 months (n=1) and 1 year (n=2) revealed decreased levels of phospho-

STAT3 (pSTAT3) in Asrij deficient mice. M indicates the marker lane. Graphs shown alongside represent the relative pSTAT3 levels in *asrij<sup>fl/fl</sup>;Cre* mice tissues, normalized with respect to STAT3 levels.

Since Asrij activates the JAK/STAT pathway, we wanted to test the *in vivo* effect of mouse Asrij on STAT3 activation. By Western blotting analysis of different age groups of *asrij<sup>fl/fl</sup>;Cre* mice tissues, we found that Asrij depletion leads to reduced levels of phospho-STAT3 (Refer Figure 4.1). These data indicate that Asrij plays a key role in promoting the phosphorylation of STAT3 and is indeed a positive regulator of the JAK/STAT pathway. **Hence, these results highlight the conserved role of Asrij, across evolution, in mediating endosomal regulation of JAK/STAT signalling.**

#### **4.3.2 Increased activation of the PI3K/Akt pathway in *asrij<sup>fl/fl</sup>;Cre* mice**

The PI3K/Akt pathway plays an important role in regulating hematopoiesis and is often the target for treatment of hematological malignancies (Kawauchi et. al., 2009). Over-activation of Akt at Serine 473 leads to myeloproliferative disorder in PTEN knockout mice causing an increase in the number of terminally differentiated blood cells (Lee et. al., 2014). We investigated the status of the PI3K/Akt pathway in *asrij<sup>fl/fl</sup>;Cre* mice. Western blotting analysis across different age groups of *asrij<sup>fl/fl</sup>;Cre* mice revealed consistently high levels of activated Akt (Serine 473) (Refer Figure 4.2). These data indicate that loss of Asrij affects Akt activation, thus, Asrij negatively regulates the PI3K/Akt pathway.

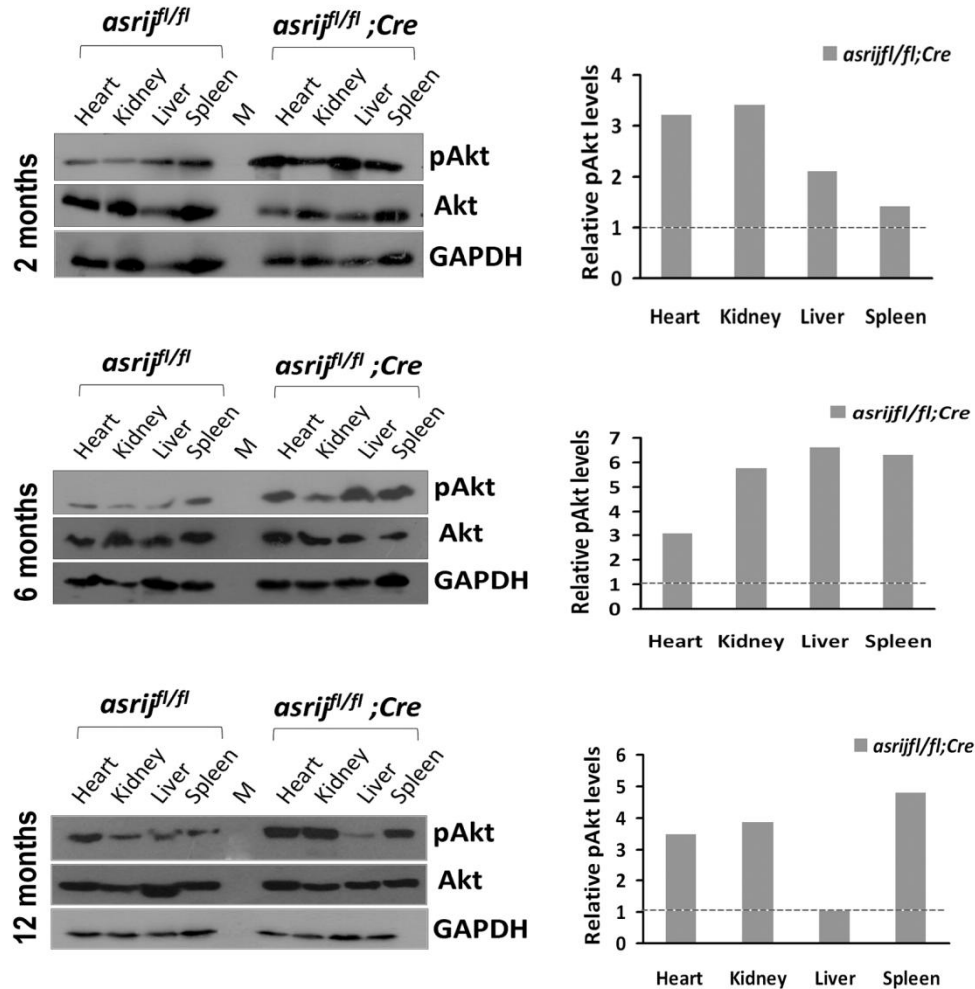
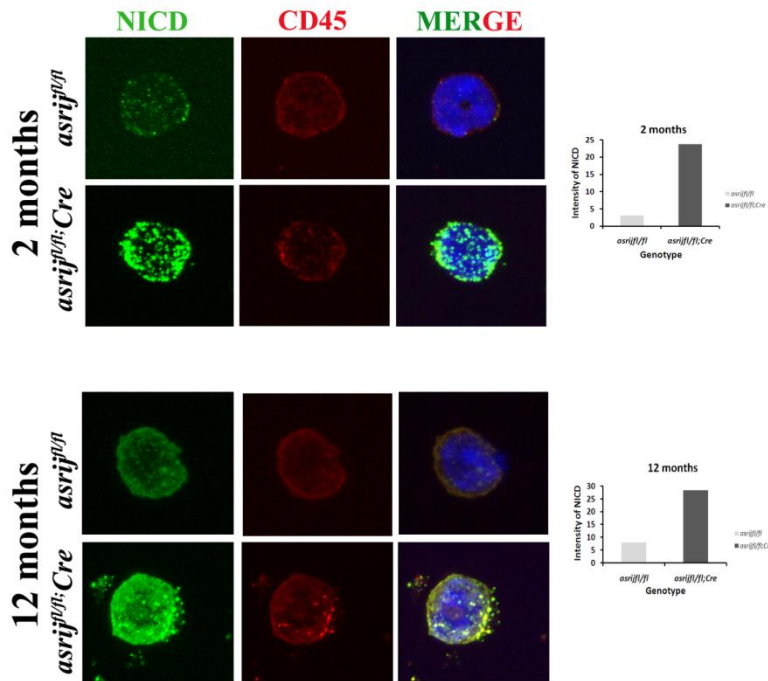

**Figure 4.2: Over-activation of the PI3K/Akt pathway in *Asrij* deficient mice.** Western Blotting performed across different ages of mice, 2 months (n=2), 6 months (n=1) and 1 year (n=2) revealed increased levels of phospho-Akt in *Asrij* deficient mice. M indicates the marker lane. Graphs shown alongside represent the increased pAkt levels in *asrij<sup>fl/fl</sup>;Cre* mice tissues, normalized with respect to Akt levels.

#### 4.3.3 *Asrij* negatively regulates the Notch pathway in mice

One of the striking phenotypes in the *Drosophila* *Asrij* null mutant was NICD entrapment in Hrs-positive sorting endosomes, correlating with increased differentiation of crystal cells. *Asrij* regulates Notch trafficking to maintain stem cell-like precursor hemocytes in the lymph gland and regulates their proliferation (Kulkarni, Khadilkar et. al., 2011). To investigate whether *Asrij* regulates Notch signalling in vertebrates, we probed the status of NICD in *asrij<sup>fl/fl</sup>;Cre* mice.

Immunostaining for NICD (Cleaved Notch 1 product) showed an enrichment of NICD in *asrij<sup>fl/fl</sup>;Cre* bone marrow cells as compared to control since 2 months of age (Refer Figure 4.3).

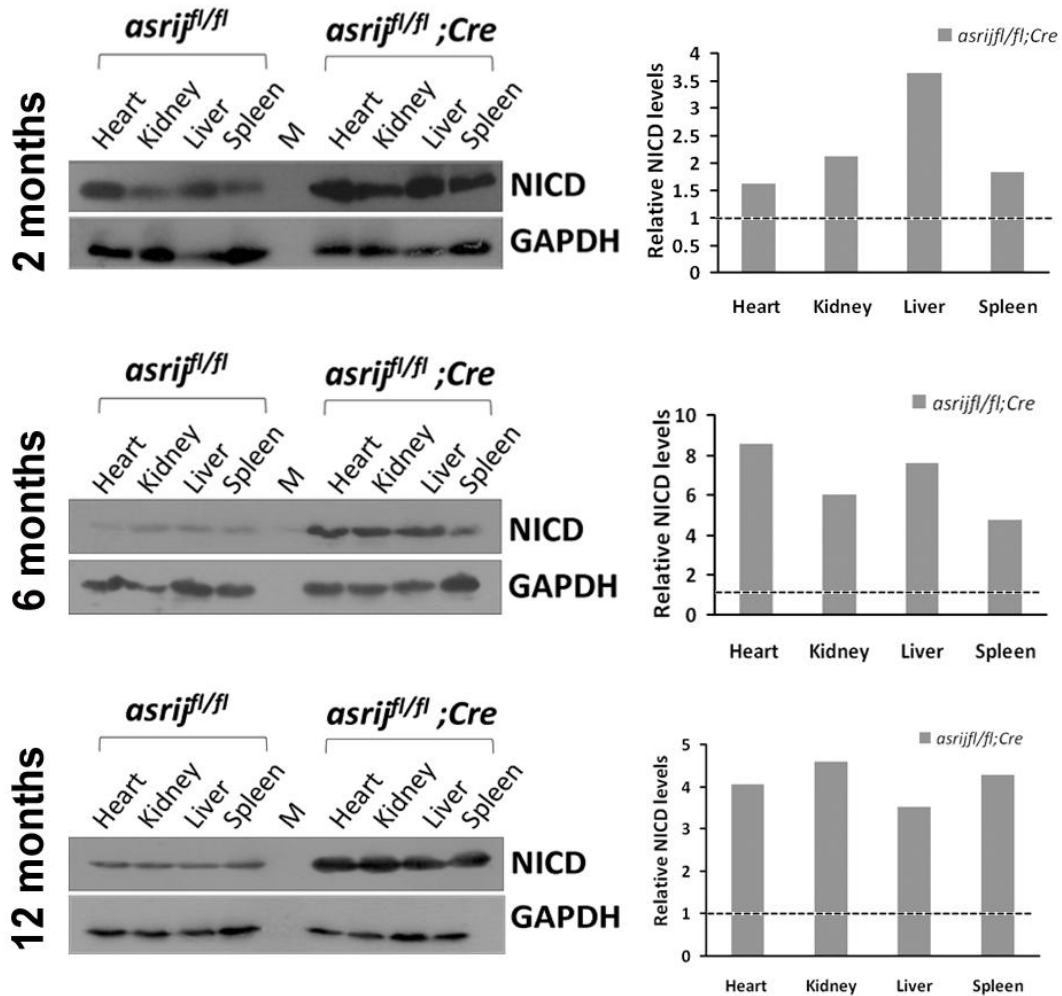

**Figure 4.3: The Notch pathway is over-activated in *Asrij* deficient mice.** Immunostaining of 2 months and 12 months old *asrij<sup>fl/fl</sup>* and *asrij<sup>fl/fl</sup>;Cre* bone marrow cells revealed increased levels of NICD (shown in green) in CD45-positive (shown in red) hematopoietic cells of the bone marrow. Nuclei were stained for DAPI (shown in blue). Imaged at 100X magnification.

In addition, immunoblotting analysis was performed for 2 months, 6 months and 12 months aged *asrij<sup>fl/fl</sup>;Cre* mice to check for similar perturbation in NICD expression. Increased levels of NICD were observed in *asrij<sup>fl/fl</sup>;Cre* mice tissues since 2 months of age (Refer Figure 4.4).

These data indicate that Notch pathway is indeed over-activated in *Asrij*-depleted conditions. **Hence, these results highlight the conserved role of *Asrij*, across evolution, in mediating endosomal regulation of the Notch signalling pathway.**

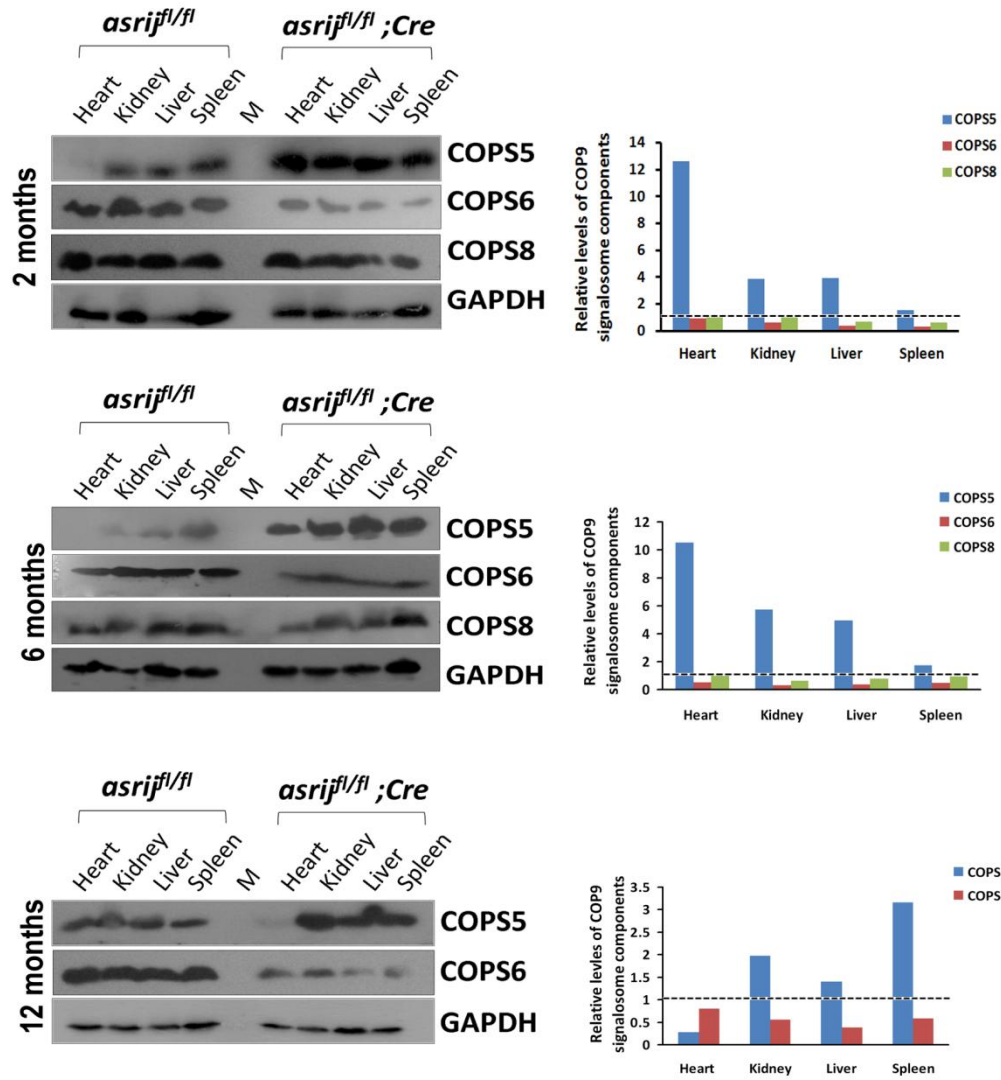



**Figure 4.4: Increased NICD levels in *asrij*<sup>fl/fl</sup>; Cre mice tissues.** Western Blotting performed across different ages of mice, 2 months (n=2), 6 months (n=1) and 1 year (n=2) revealed increased levels of cleaved Notch-1 in *Asrij* deficient mice. M indicates the marker lane. Graphs shown alongside represent the increased NICD levels in *asrij*<sup>fl/fl</sup>; Cre mice tissues, normalized with respect to NICD levels in the control tissues.

#### 4.3.4 *Asrij* regulates expression of the COP9 signalosome components

The COP9 signalosome is an evolutionary conserved protein complex that functions at the interface of signal transduction and ubiquitin mediated protein degradation (Otschir et. al., 2002). It consists of eight distinct subunits (COPS 1 to 6, COPS7a, COPS7b and COPS8) and is highly homologous to the lid sub-complex of 26S proteasome (Wei et. al., 2003).



**Figure 4.5: Expression of COP9 signalosome components affected in *asrij<sup>fl/fl</sup>;Cre* mice.** Western Blotting performed across different ages of *asrij<sup>fl/fl</sup>;Cre* mice, 2 months (n=2), 6 months (n=1) and 1 year (n=2) revealed increased levels of COPS5 in *Asrij* deficient mice. COPS6 levels were dramatically reduced but no difference in the expression of COPS8. M indicates the marker lane.

Analyses of global gene expression in *Asrij* modulated mouse embryonic stem cells showed perturbation of several COP9 signalosome components (A. Sinha thesis, 2013). We wanted to test the *in vivo* effects of *Asrij* deletion on the COP9 signalosome. Western blotting analysis across 2 months, 6 months and 12 months age groups of *asrij<sup>fl/fl</sup>;Cre* mice validated that *Asrij* indeed dynamically regulates the expression levels of different components of the COP9 signalosome. Tissues of *Asrij* deficient mice showed increased levels of COPS5 and

decreased levels of COPS6, whereas the expression of COPS8 was not perturbed (Refer Figure 4.5).

#### 4.3.5 Increased ubiquitin levels in *asrij<sup>fl/fl</sup>;Cre* mice

Asrij depletion showed ubiquitin accumulation in both *Drosophila* lymph gland cells and circulating hemocytes, indicating a cargo sorting defect (Khadilkar thesis, 2014). To test whether mouse Asrij regulates cargo sorting, we checked for accumulation of ubiquitin moieties by immunostaining with an antibody that recognizes mono- as well as poly-ubiquitin moieties. Immunostaining results showed a dramatic increase in ubiquitin levels in Asrij deficient mice as compared to control mice (Refer Figure 4.6). The results obtained were consistent across 2 months, 6 months and 12 months aged *asrij<sup>fl/fl</sup>;Cre* mice.

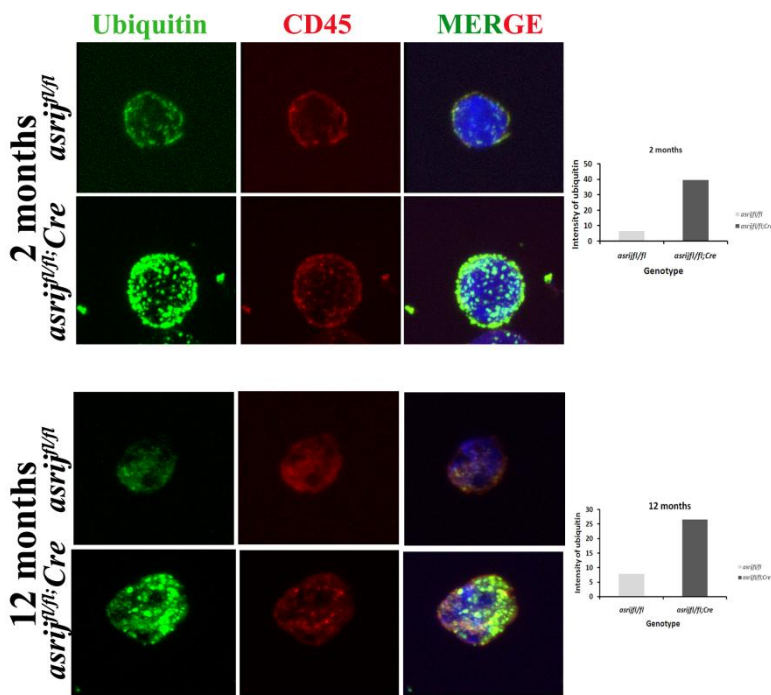

**Figure 4.6: Increased ubiquitin levels in Asrij deficient mice.** Immunostaining of *asrij<sup>fl/fl</sup>* and *asrij<sup>fl/fl</sup>;Cre* bone marrow cells revealed increased levels of ubiquitin (shown in green) in CD45 (shown in red) hematopoietic cells of the bone marrow. Nuclei were stained for DAPI (shown in blue). Imaged at 100X magnification.

We also performed ubiquitin immunoblotting across 2 months, 6 months and 12 months aged *asrij<sup>fl/fl</sup>;Cre* mice and observed a dramatic increase in ubiquitin levels in Asrij deficient mice tissues as compared to control mice tissues (Refer Figure 4.7). The results obtained were consistent across all ages of *asrij<sup>fl/fl</sup>;Cre* mice.

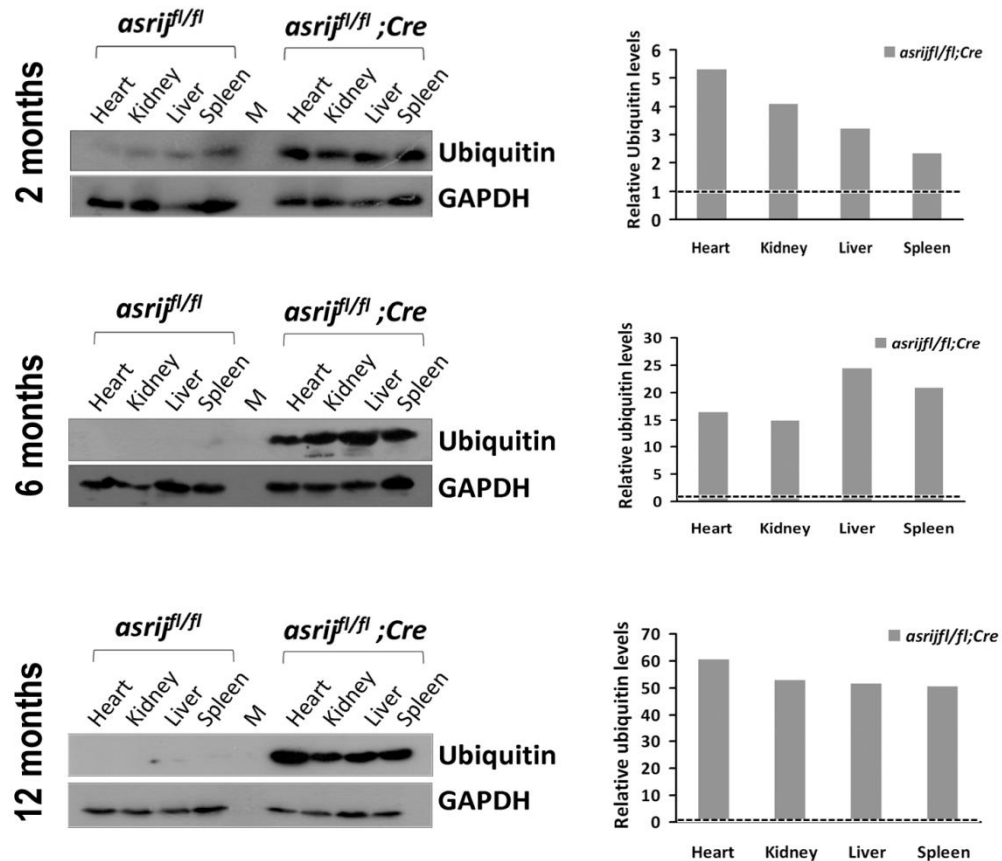

**Figure 4.7: Increased ubiquitin levels in *asrij<sup>fl/fl</sup>;Cre* mice tissues.** Western Blotting performed across different ages of mice, 2 months (n=2), 6 months (n=1) and 1 year (n=2) revealed increased levels of ubiquitin in *Asrij* deficient mice. M indicates the marker lane. Graphs shown alongside represent the increased ubiquitin levels in *asrij<sup>fl/fl</sup>;Cre* mice tissues, normalized with respect to ubiquitin levels in the control tissues.

#### 4.4 Discussion

Complex signalling networks mediate different cellular functions, but how these signals integrate is not completely known. To understand the coordination and integration of developmental signals, we chose to analyze the role of endocytic molecules. The results presented in this chapter have helped in understanding the status of different signalling pathways in *Asrij* depleted conditions. More importantly, it sheds light on how an endocytic molecule coordinates different signalling pathways for regulation of the mouse hematopoietic system.

#### **4.4.1 *Asrij* positively regulates the JAK/STAT pathway**

STAT3 is a nuclear transcription factor, required for proper regulation of bone marrow HSCs and HPCs (Mantel et. al., 2012). Various reports suggest that STAT3 associates with the endosomes for promoting its phosphorylation, after which it translocates to the nucleus for downstream activation of target genes (Shah et. al., 2006; Sehgal, 2008). Over-activation of the JAK/STAT signalling is the leading cause for various hematological disorders (Vainchenker et. al., 2003). On the other hand, inhibition of STAT3 signalling leads to demonstration of enhanced anti-tumor activity by immune cells and is considered to be a marker of tumor immune surveillance activity (Kortylewski et. al., 2005).

Previous studies have highlighted the role of *Asrij* as a positive regulator of the JAK/STAT pathway (Sinha et. al., 2013). On probing the status of STAT3 in *Asrij* perturbed genetic background, we found reduced levels of activated STAT3 in mouse tissues such as heart, kidney, liver and spleen. Phosphorylated but not total STAT3, was inhibited in these tissues in the absence of *Asrij*.

Analysis of the JAK/STAT pathway in the bone marrow compartment of *Asrij<sup>fl/fl</sup>;Cre* mice is important and needs to be investigated in future to check whether loss of *Asrij* affects the levels of activated STAT3 in the HSCs.

#### **4.4.2 *Asrij* negatively regulates the PI3K/Akt pathway**

The PI3K/Akt pathway is central to many biological processes such as cell survival and proliferation, apoptosis and insulin metabolism. Phosphorylation of the serine threonine kinase, Akt, results in activation of downstream targets majorly involved in regulation of cell survival and growth (Manning et. al., 2007). Dysregulation of the PI3K/Akt pathway has been implicated in several human malignancies. Mutations leading to constitutive activation of Akt cause cancers such as breast cancer, lung cancer and colon carcinomas (Samuels et. al., 2004).

Constitutive activation of Akt confers leukemogenic potential to hematopoietic stem cells (Horn et. al., 2008). The consequences of Akt activation have been well studied using conditional and constitutive PTEN knockout mouse models. Conditional HSC-specific deletion of PTEN from mice using MxCre results in development of myeloproliferative disorder, which eventually progresses to give rise to either acute myeloid leukemia (AML) or T-cell acute lymphoblastic leukemia (T-ALL) (Yilmaz et. al., 2006; Zhang et. al., 2006; Tesio et. al., 2013). On the contrary, studies done using global PTEN knockout mouse model, has shown that constitutively active Akt induces premature exhaustion of the stem cell pool leading to increased production of terminally differentiated blood cells, thereby resulting in a myeloproliferative disorder.

*asrij<sup>fl/fl</sup>;Cre* mice tissues exhibit increased levels of activated Akt, suggesting that *Asrij* is a negative regulator of the PI3K/Akt pathway in mice. Induction of constitutive Akt signalling in *asrij<sup>fl/fl</sup>;Cre* mice may lead to an increase in the LT-HSC and ST-HSC sub-populations and eventual exhaustion of the stem cell pool or progression to leukemia.

#### **4.4.3 *Asrij* modulates Notch trafficking**

Notch trafficking dynamics is dramatically affected in *Asrij* depleted conditions. We report that *Asrij* negatively modulates the Notch pathway by regulating the trafficking of cleaved Notch 1 product (NICD). Our analysis using bone marrow cell- based immunostaining indicates that *Asrij* plays an important role in regulating the dynamics of Notch trafficking. Increased levels of NICD confirm over-activation of the Notch pathway in *asrij<sup>fl/fl</sup>; Cre* mice. In RAG knockout mice, increase in the levels of activated Notch 1 leads to increased stem cell counts. Serial transplantation assays confirmed that the increase in stem cell numbers was due to the enhanced self-renewal ability of the HSCs in the presence of activated Notch1 (Stier et. al., 2000).

Previous studies in *Drosophila* have shown that Asrij modulates Notch trafficking to control hemocyte differentiation (Khadilkar thesis, 2014). We hypothesize that increased levels of NICD in *asrij<sup>fl/fl</sup>; Cre* mice might lead to changes in the bone marrow stem cell counts and also affect differentiated blood cell counts.

#### **4.4.4 *Asrij* affects expression of the COP9 signalosome components**

The COP9 signalosome has been very well studied and is known to regulate different pathways (Wei et. al., 2008). In *Drosophila* germline stem cells (GSCs), the activity of COP9 signalosome to regulate stemness or differentiation is based on a protein competition mechanism (Lei et. al., 2014). Thus, expression of the various subunits of the COP9 signalosome does play a major role in deciding the fate of a stem cell. The status of COP9 signalosome components in Asrij depleted conditions suggests that Asrij differentially regulates the expression of each subunit. Asrij depletion affects the expression of COP5 and COPS6 and it is likely that Asrij physically interacts with one or more subunits of the COP9 signalosome. Loss of Asrij did not affect the expression of COPS8.

COPS5, also known as CSN5 or JAB1 (Shackelford et. al., 2010), is a monomeric protein that plays an essential role in the proliferation and survival of mammalian cells (Kato et. al., 2009). It is a marker of malignant transformation (Luo et. al., 2009) and ectopic expression of a stable form of COPS5 induces myeloproliferative disorder in mice along with expansion of stem cell population (Mori et. al., 2008). Western blotting analysis across different ages of *asrij<sup>fl/fl</sup>; Cre* mice revealed increased levels of COPS5. This data strengthens our hypothesis of a myeloproliferative disorder in *asrij<sup>fl/fl</sup>; Cre* mice and suggests that overexpression of COPS5 drives expansion of the bone marrow HSC population.

COPS6, a 297 amino acid containing protein, encodes a putative deubiquitinase, which has been reported to play important roles in early embryonic development in zebrafish (Tse et.

al., 2011). *asrij<sup>fl/fl</sup>;Cre* mice showed reduced expression levels of COPS6. Reduction in the expression levels of COPS6 affects the stability of E3 ubiquitin ligases and this might possibly account for the increased ubiquitination observed in *Asrij* deficient mice.

These data suggest the need for more detailed studies of the role(s) of *Asrij* in regulation of COP9 signalosome and raise the idea that COP9 signalosome could be used as a potential therapeutic target for treatment of various blood disorders.

#### **4.4.5 *Asrij* depletion leads to increased ubiquitin levels**

Regulated activity of ubiquitin ligases and deubiquitinases governs the abundance and stability of cellular proteins (Reavie et. al., 2010). Ubiquitin ligases tag proteins with mono- or poly-ubiquitin moieties, these ubiquitinated proteins are then transported to the lysosomes by the endosomal sorting complex for transport (ESCRT) machinery for their destruction (Raiborg and Stenmark, 2009). Lysosomal degradation of internalized membrane proteins is an important process required for signal attenuation. Components of the ESCRT machinery recognize and bind ubiquitinated cargo in a sequential manner. Impaired activity of ubiquitin ligases and their opposing deubiquitinases or failure of the ESCRT machinery may lead to accumulation of ubiquitinated cargo.

The fate of a hematopoietic stem cell is not only subject to regulation by several cell-intrinsic and cell-extrinsic cues but is also regulated by post-translational modifications such as ubiquitination. The ubiquitin complex is an important regulator of stem cell function and differentiation. Ubiquitination plays a major role in deciding the stability and abundance of cellular factors that govern HSC fate and is thus central to regulation of hematopoiesis. Ubiquitination plays an important role in regulating the stability of proteins and thus affects the gene expression signature of HSCs (Reavie et. al., 2010).



Asrij depleted lymph glands and circulating hemocytes show accumulation of ubiquitin moieties (Khadilkar thesis, 2014). Analysis of ubiquitin expression levels in tissues and the bone marrow hematopoietic compartment reflect that loss of Asrij dramatically affects ubiquitination. Increased ubiquitin levels in *asrij<sup>fl/fl</sup>;Cre* mice could be the result of perturbation in the balanced activity of ubiquitin ligases or their opposing deubiquitinases. It suggests the possibility of a sorting defect that results upon Asrij depletion, indicating either a delay in degradation or absence of progression of the ubiquitinated cargo towards the lysosomal or proteasomal degradation machinery. Alterations in ubiquitination and degradation lead to the formation of tumor-initiating cells and contribute to the development of hematological malignancies (reviewed in Strikoudis et. al., 2014).

Based on the Notch and ubiquitin accumulation phenotypes observed, it is likely that Asrij could be a part of the ESCRT machinery which will have to be tested further.

#### **4.5 Concluding remarks**

Endosomes and endosomal associated proteins play a more active role in signal transduction than was previously thought (Seghal, 2008). As an endosome associated protein, Asrij seems to be acting as the nodal connection among several signalling pathways, as it selectively regulates the activation or inhibition of signalling components. The physical platform provided by Asrij-positive endosomes aids in the regulated propagation of several signalling circuitries for maintenance of hematopoiesis. Our analysis of *asrij<sup>fl/fl</sup>;Cre* mice, with increased levels of NICD, ubiquitin, COPS5 and activated Akt along with decreased levels of COPS6 and activated STAT3, has revealed perturbation of major signalling pathways governing hematopoiesis.

Over-activation of Notch 1 enhances self-renewability of stem cells, leading to an increase in the numbers of stem cells in the bone marrow and prefers lymphoid over myeloid lineage outcome (Stier et. al., 2002). Constitutive activation of Akt in PTEN global knockout mouse models leads to premature exhaustion of the stem cell pool and induces myeloproliferative disorder (Lee et. al., 2014). HSC-specific deletion of STAT3 from mice significantly increases the bone marrow population (Mantel et. al., 2012). Ectopic expression of COPS5, a component of the COP9 signalosome induces myeloproliferative disorder in mice (Mori et. al., 2008). Taken together, perturbation of key molecules of several signalling pathways such as Notch, PI3K/Akt, JAK/STAT and components of the COP9 signalosome such as COPS5 takes a toll on the bone marrow hematopoietic compartment either leading to expansion of LT-HSC and ST-HSC sub-populations or leading to premature exhaustion of the stem cell pool. Being an endosomal protein Asrij is well-positioned to co-ordinate multiple signals. Hence any perturbation of Asrij could be expected to simultaneously affect the above pathways. Our data suggests that Asrij is pivotal to bring about differential modulation of signals and regulate mouse hematopoiesis.

## **Chapter 5: Phenotypic analysis of *asrij* knockout mice tissues.**

### **5.1 Introduction**

Immunoblotting and immunostaining analyses of *Asrij* knockout mouse tissues (described in Chapter 4) revealed perturbation of several signalling pathways that play a conserved role in hematopoiesis, indicating perturbed tissues homeostasis. As mentioned before, vertebrates have shifting sites of hematopoiesis across different developmental stages. Thus, we chose to study the effect of *Asrij* knockout on the morphology of hematopoietic tissues such as bone marrow and spleen.

The bone marrow consists of different types of cells such as HSCs, HPCs and the terminally differentiated blood cells, adipocytes and macrophages. It is important to note that these cells are not arranged in a random fashion but demonstrate a particular organization within the bone marrow (Weiss and Geduldig et. al., 1991). Hematopoiesis is a compartmentalized process, where the tissue has well-demarcated units for erythropoiesis, granulopoiesis and megakaryopoiesis (Jain, 1986; Hoffman et. al., 2000; Gasper, 2000; Abboud and Lichtman, 2001). Thus, maintenance of bone marrow architecture is important for formation of various blood cells.

Apart from bone marrow, spleen plays an important role in hematopoiesis. The spleen is the major lymphatic and hematological organ which is known to be a storehouse for RBCs and platelets (Mills et. al., 1927; Robertson et. al., 1915). It plays an active role in production of lymphocytes which act as the first line of defence upon any immune challenge (Crosby, 1983). Various hematological malignancies are associated with splenomegaly. It is the most common physical finding that constitutes one of the initial symptoms leading to the diagnosis of several

hematological disorders (Uranus, 2001), such as, chronic lymphocytic leukemia, acute lymphoblastic leukemia, chronic myeloid leukemia and hairy cell leukemia (Lihteh, 2014).

This chapter presents the results obtained from phenotypic and histological analysis of various Asrij knockout mice tissues.

## **5.2 Materials and Methods**

### **5.2.1 Radiography of mice**

Mice to be taken for soft X-ray analysis were sedated with a combination of ketamine HCl (Ketamil, Troy Laboratories) and xylazine HCl (Ilium Xylazil-20, Troy Laboratories) (0.1 ml/kg of body weight of mouse) administered by intraperitoneal injection. Mice were then laid laterally on radiographic cassettes and radiodense (metal) numbers were placed on the cassette for indicating the mouse number. Optimum exposure to the radiography film was established at 40kV, 1.5mA, using a portable X-ray unit (CUPA, Bangalore).

### **5.2.2 Alcian Blue and Alizarin Red Staining**

Mice were dissected by removing skin and organs completely. Utmost care was taken so that no damage was done to the skeleton of the mouse. Specimens were washed thoroughly with phosphate buffer saline (PBS) (8g sodium chloride, 0.2g potassium chloride, 1.44g disodium hydrogen phosphate, 0.24g of potassium dihydrogen phosphate dissolved in 1 litre of distilled water, pH set to 7.4) and then fixed in 95% ethanol for 12-48 hours at room temperature. Fixing solution was replaced with 0.3% Alcian Blue (Alcian Blue 8GX; SIGMA, Catalogue No. A5268) solution and incubated for 1 to 3 days at room temperature. After Alcian Blue staining was complete, the skeleton was washed with 100% ethanol for 1 hour and then replaced with 70% ethanol for overnight washing. After removal of excess Alcian Blue stain,

the skeleton was kept in 1% trypsin (Trypsin 1:250 SDFCL, Catalogue no. 49040 G25) solution made in buffer [30% sodium borate (Disodium Tetraborate Decahydrate, SDFCL, Catalogue No.: 20267K05) solution] for muscle digestion. When the skeleton turned limp, it was kept in 2% KOH for 12 to 24 hours, followed by 0.1% Alizarin Red (Alizarin Red S, SIGMA, Catalogue No. A5533) staining for 12 to 24 hours. For clearing, the skeleton was successively passed through 10%, 30%, 50%, 70%, 90% and 100% glycerol (Glycerol anhydrous, MERCK, Catalogue no. DK4D640582). After completion of bone and cartilage staining, skeleton was preserved in 100% glycerol with a pinch of sodium azide (Sodium Azide, MERCK, Catalogue No. MD9M590905). These experiments were done with the help of B.V.Anudeep.

### **5.2.3 Bone marrow processing for cryosectioning**

Femurs harvested from *asrij<sup>fl/fl</sup>* and *asrij<sup>fl/fl</sup>;Cre* mice were washed in PBS and immediately stored in ice-cold 4% paraformaldehyde (Merck, Millipore, USA) for overnight fixation. Following fixation, bones were transferred to freshly prepared 0.5mM EDTA solution (Catalogue No.: TC038, Himedia Laboratories) for 48 hours for decalcification. Bones were thoroughly washed in PBS and equilibrated in 30% sucrose in PBS followed by equilibration at 4°C in tissue freezing medium (Jung, Leica Microsystems, Wetzlar, Germany). Tissues were stored at -80 °C until further use.

### **5.2.4 Cryosectioning**

Microscopy slides were washed thoroughly with soap water, then with 1.2% chromic acid (Qualigen, Fisher Scientific, USA) and soaked in a solution of 1% Gelatin (SIGMA, Chemical Co. USA) (w/v) and 0.1% Potassium chromate (Qualigen, Fisher Scientific, USA) (w/v) at 55<sup>0</sup> C for 6 hours. The slides were air dried and stored at room temperature until used. Frozen tissue blocks were prepared in OCT (Catalogue Number: 14020108926, Tissue Freezing

Medium, Leica) compound, sectioned at 10 µm using a Leica cryostat (CM3050 S, Leica, Wetzlar, Germany) and collected on gelatine coated slides.

### **5.2.5 Paraffin sectioning**

Harvested tissues were fixed with 4% paraformaldehyde overnight and were successively dehydrated through 30%, 50%, 70%, 90% and 100% ethanol for two hours each at room temperature followed by two xylene incubations. Dehydrated tissues were infiltrated with molten paraffin (Catalogue No: 107174, Merck, Darmstadt, Germany) at 60 °C, with one change of paraffin, one hour each, cast in suitable moulds and cooled at 4 °C for at least 2 to 3 hours and sectioned at 5 µm using a microtome (Leica RM 2135, Leica Biosystems). Sections were expanded by floating on warm water maintained at 55 °C, collected on gelatin-coated slides, air dried, kept at 60 °C for 30 minutes and stored at room temperature. Before hematoxylin and eosin staining, sections were deparaffinized by incubating the slides at 56 °C for 45 minutes to melt away the paraffin. These experiments were also performed with help from B.V.Anudeep.

### **5.2.6 Hematoxylin and eosin (H&E) staining**

Slides bearing tissue cryosections were air-dried for 10-15 minutes and incubated in acetone for 10 minutes, hydrated through a graded series of alcohol (100%, 90%, 70%, 50% ethanol) for 5 minutes each followed by a rinse in distilled water and stained with neat hematoxylin (Catalogue No. 38803, Delafield's, Qualigens, Fisher Scientific) for 12 to 15 seconds. Slides were then washed under gently running tap water for 20 minutes. For Eosin staining, slides were dehydrated through graded series of alcohol (50%, 70%, 90%, 100% ethanol) for 10 minutes each and dipped in Eosin Y (cat. no. HT 110116, SIGMA Chemical Co., USA), followed by a dip in 100% ethanol and then finally incubated in Xylene (Qualigens, Fisher Scientific, USA) for 7 minutes.

### 5.2.7 Microscopy and Imaging

H&E stained slides mounted in dibutyl polystyrene xylene (DPX; Qualigen, Fisher Scientific, USA) were imaged in brightfield using an IX70 inverted microscope (Olympus, Tokyo, Japan).

## 5.3 Results

### 5.3.1 Soft X-ray analysis reveals kyphosis in *asrij<sup>fl/fl</sup>;Cre* mice

The most striking phenotype observed after visual inspection of live as well as deceased, one year old, *asrij<sup>fl/fl</sup>;Cre* mice was the presence of skeletal defects (Refer Figure 5.1).

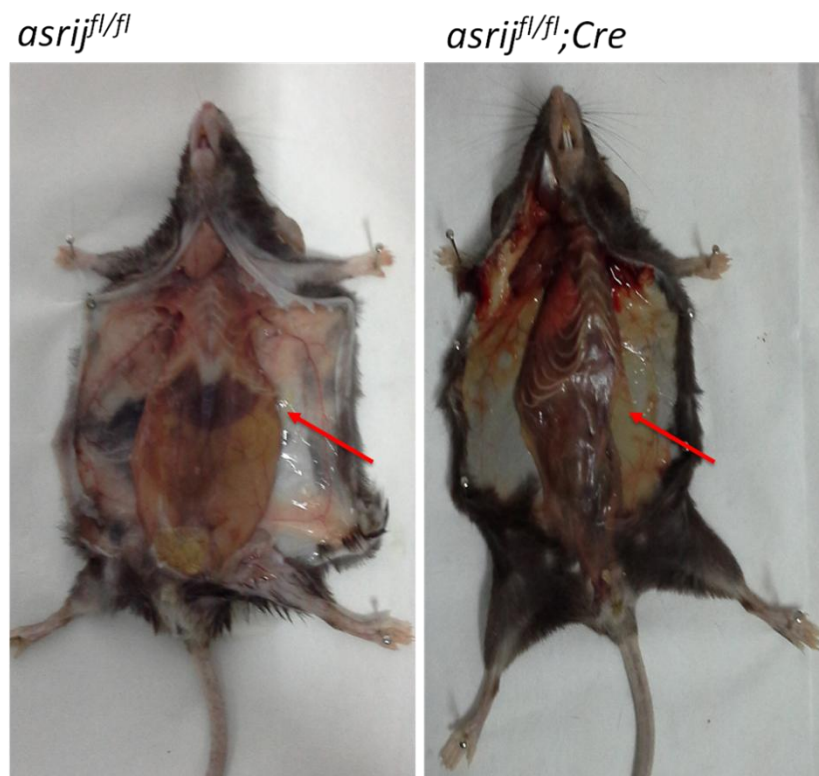
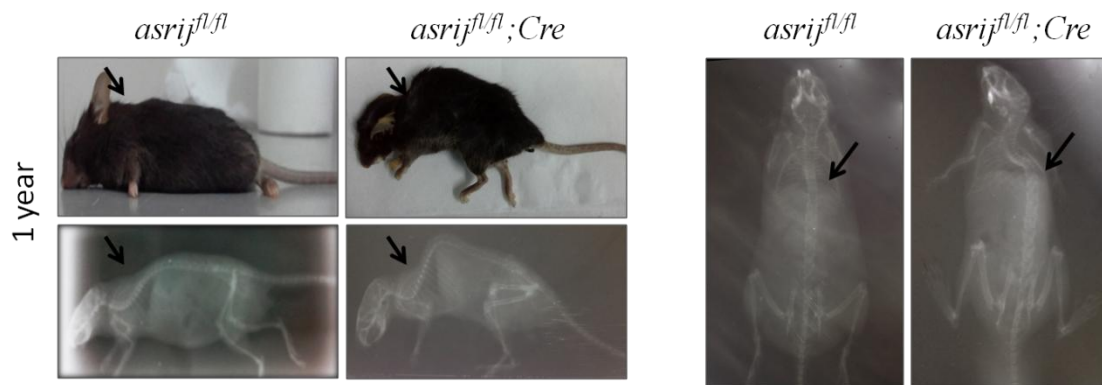

Figure 5.1: Necropsies of 1 year old *asrij<sup>fl/fl</sup>;Cre* mice revealed skeletal defects, generic tissue deterioration and splenomegaly.

In order to investigate what the skeletal defect was, we performed soft X-ray analysis of the 1 year old *asrij<sup>fl/fl</sup>;Cre* mice. The radiographs revealed pronounced kyphosis, a type of spinal deformity, which was characterized by an increased curvature of cervico-thoracic spine. In addition to the disorganized and irregular curvature of the spine, *asrij<sup>fl/fl</sup>;Cre* mice also showed altered arrangement of hindlimbs. We calculated the Cobb's angle, which is a measure of spinal deformity, for quantifying the degree of kyphosis. The Cobb's angle for 1 year old *asrij<sup>fl/fl</sup>* mice was  $38 \pm 5^\circ$  whereas for *asrij<sup>fl/fl</sup>;Cre* mice was  $70 \pm 0.3^\circ$  (Refer Figure 5.2).

A)



B)

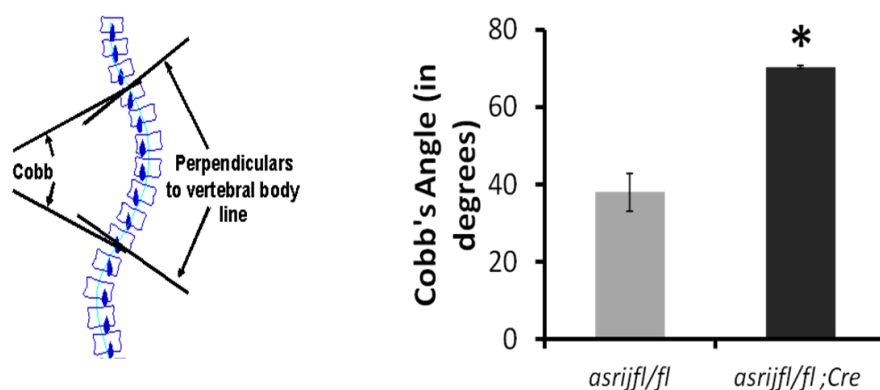
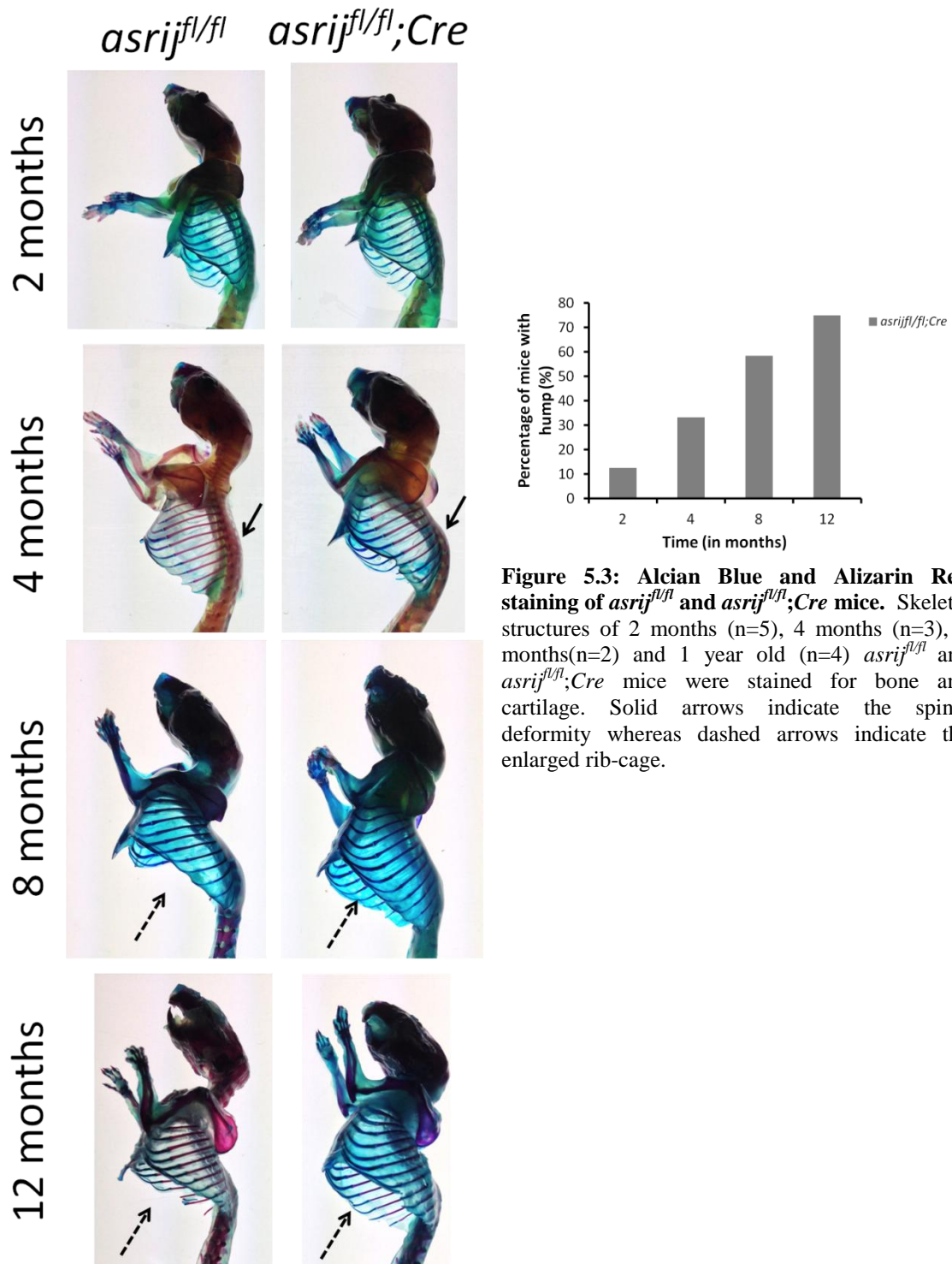

**Figure 5.2: Development of skeletal defects in adult *asrij<sup>fl/fl</sup>;Cre* mice. A) Radiography** of adult (1 year old) *asrij<sup>fl/fl</sup>;Cre* mice (n=12) showed the presence of a hump (solid black arrows) and excessive muscle wastage. **B) Cobb's angle schematic and quantitation for *asrij<sup>fl/fl</sup>* and *asrij<sup>fl/fl</sup>;Cre* mice.** Schematic representing Cobb's angle (Modified from [www.srs.org](http://www.srs.org)) *asrij<sup>fl/fl</sup>;Cre* mice showed a significant increase in the kyphotic spine deformity ( $p < 0.05$ ). (X-rays obtained from CUPA, Bangalore; Acknowledgement: Jasper Chrysolite Paul and Shrinivas Dighe).



Apart from this, a common observation in the *asrij<sup>fl/fl</sup>;Cre* mice was muscle atrophy, a condition termed as cachexia, which involves wastage of adipose tissue and skeletal muscle.

In order to check when the skeletal defect sets in the *Asrij* deficient mice, we performed an age-dependent analysis. We concluded that *Asrij* mutant mice were not born with the



skeletal defects, but developed them with the passage of time. To further characterize the skeletal abnormalities of *asrij<sup>fl/fl</sup>;Cre* mice, we performed Alcian Blue and Alizarin Red staining of the formalin-fixed spines, that allowed simultaneous visualization of the cartilage and mineralized tissues (bone). Staining bone and cartilage for different ages of *asrij<sup>fl/fl</sup>* and *asrij<sup>fl/fl</sup>;Cre* mice showed that younger mice upto 2 months of age had no obvious skeletal defects. But we observed skeletal defects such as hump in 4 months old mutant mice and enlarged rib-cages in 8 months and 12 months old mutant mice, although the number of ribs in the wild-type and mutant were equal (Refer Figure 5.3). These data indicate that *asrij<sup>fl/fl</sup>;Cre* mice are born normal but develop skeletal abnormalities as they age.

### **5.3.2 Loss in cellularity of marrow upon *Asrij* deletion**

Bone marrow histology aids in morphological evaluation of marrow cellularity, which can be classified into three types based on density of hematopoietic tissue islands and number of adipose cells, viz., hypocellular, normocellular and hypercellular. We examined the bone marrow architecture across different age groups of *asrij<sup>fl/fl</sup>* as well as *asrij<sup>fl/fl</sup>;Cre* mice. We did not observe any gross difference in the marrow cellularity in the first two months of age between the control and mutant mice but we observed a drastic reduction in cellularity at 3 months of age (Refer Figure 5.4). These data indicate that *Asrij* deficiency results in loss of bone marrow cellularity.

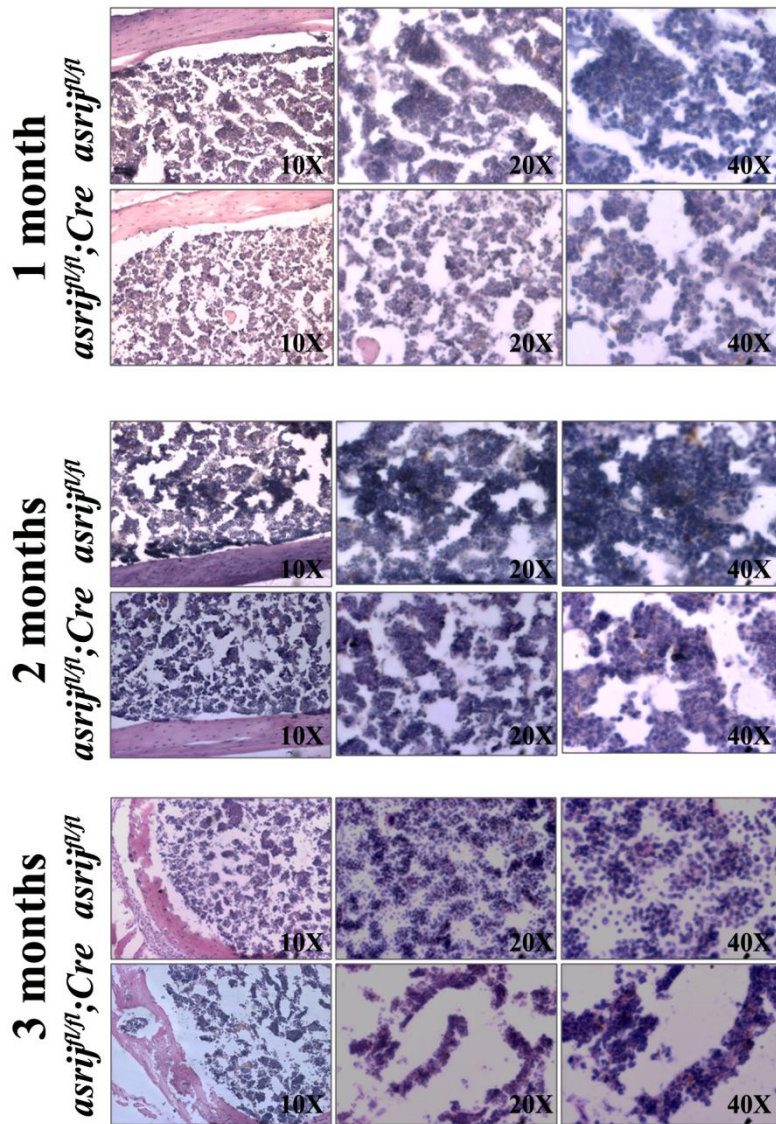
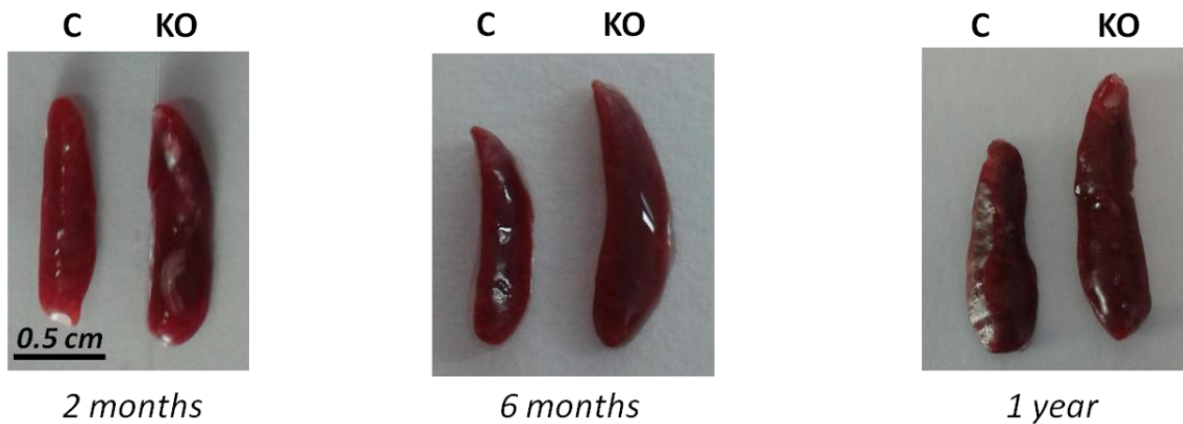

**Figure 5.4: Evaluation of *asrij<sup>fl/fl</sup>;Cre* mice bone marrow architecture.** 10X, 20X and 40X magnifications of the femoral marrow from different ages of *asrij<sup>fl/fl</sup>* and *asrij<sup>fl/fl</sup>;Cre* mice (n=1 for each age).

### 5.3.3 Splenomegaly in *asrij<sup>fl/fl</sup>;Cre* mice

Perturbed hematopoiesis in *asrij<sup>fl/fl</sup>;Cre* mice was seen to be associated with severe splenomegaly. Compared to controls, *asrij<sup>fl/fl</sup>;Cre* mice exhibited an age-dependent increase in the spleen size. A significant increase in the spleen weight was observed in *asrij<sup>fl/fl</sup>;Cre* mice from 6 months of age (Refer Figure 5.5).

A)



B)

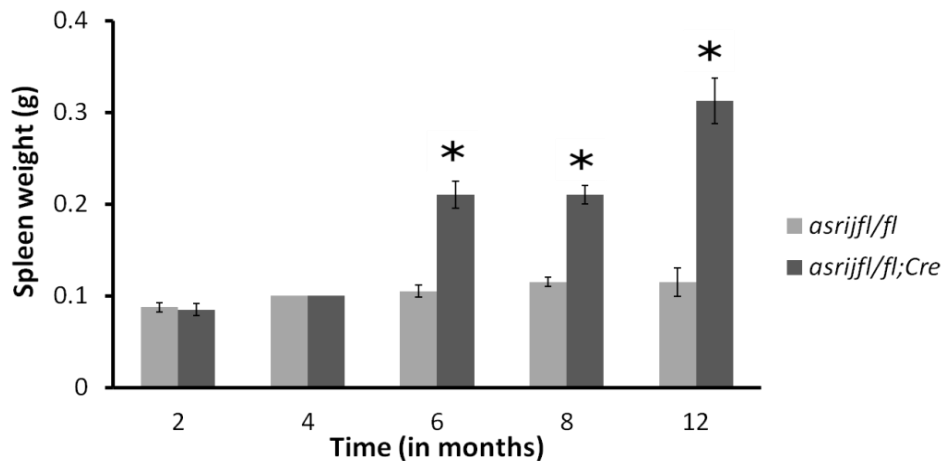

**Figure 5.5: Deletion of *Asrij* results in splenomegaly.** A) Representative photographs of spleens harvested from 2 months, 6 months and 1 year old *asrij<sup>fl/fl</sup>* and *asrij<sup>fl/fl</sup>;Cre* mice B) Spleens were weighed and compared to their wild-type counterparts. A significant increase ( $p < 0.01$ ) in spleen weight was observed in 6, 8 and 12 months old *asrij<sup>fl/fl</sup>;Cre* mice.

To further characterize splenomegaly in *asrij<sup>fl/fl</sup>;Cre* mice, we examined the histology of spleen isolated from different ages of *asrij<sup>fl/fl</sup>;Cre* mice. Paraffin sectioning followed by hematoxylin and eosin staining revealed that 1 year old *asrij<sup>fl/fl</sup>;Cre* mice developed severe hyperactive white pulp which was evident from the enlarged lymphoid nodules in the spleen (n=2) (Refer Figure 5.6).



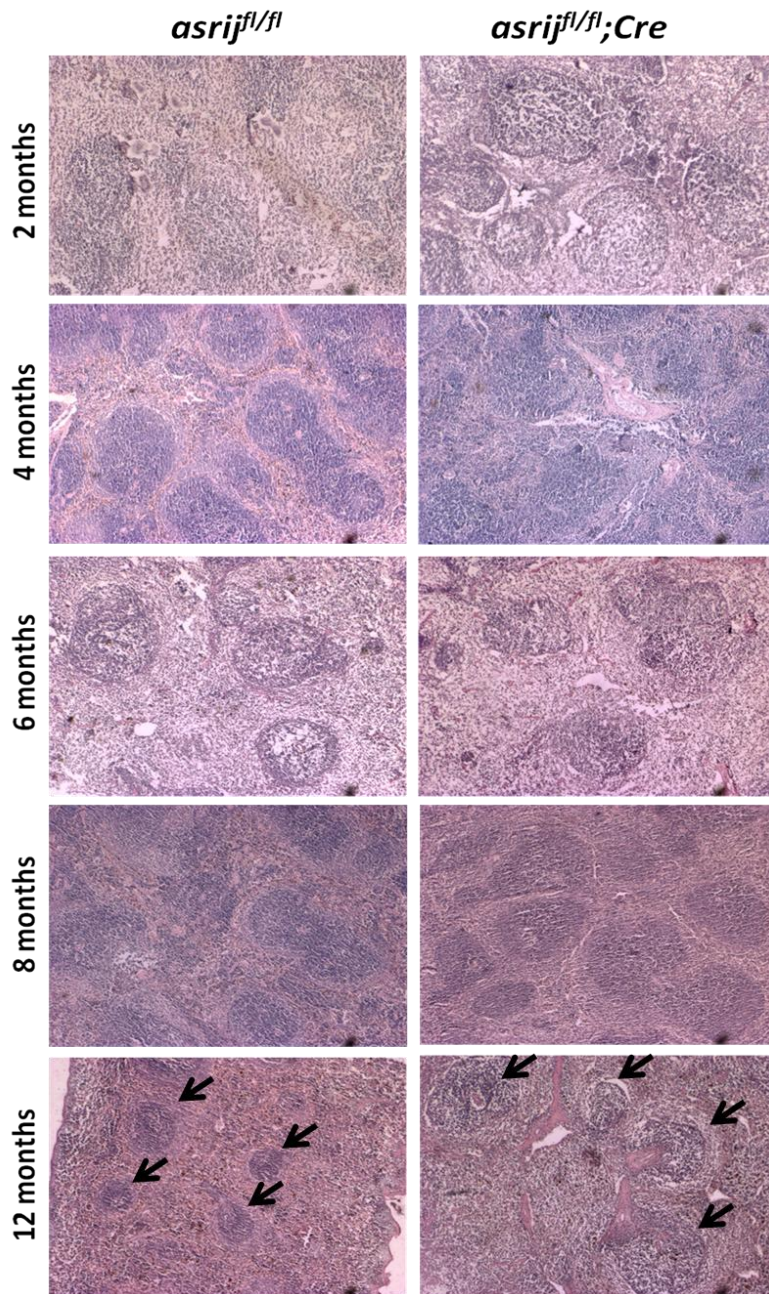

**Figure 5.6: Histological analysis of spleens across different ages of *asrij<sup>fl/fl</sup>* and *asrij<sup>fl/fl</sup>;Cre* mice.** Representative images of paraffin sections (5 $\mu$ m) of spleens isolated from 2 months, 4 months, 6 months, 8 months and 12 months old *asrij<sup>fl/fl</sup>;Cre* mice (n=2 for each). Enlarged lymphoid nodules (spherical or ovoid aggregations shown using bold black arrows)

#### 5.4 Discussion

Phenotypic analysis of *Asrij* null mice indicates generic deterioration of organ systems with age. Systemic loss of *Asrij* from mice results in skeletal abnormalities with increasing age, such as cervico-thoracic kyphosis and altered morphology of hematopoietic organs such as bone marrow and spleen.

Here, we report that mice lacking an endosomal protein *Asrij* suffer from severe skeletal malformations. It is not surprising that a number of studies have reported that loss of activity of endosomal proteins or of proteins functioning in the endocytic route(s) often leads to skeletal abnormalities and myopathies. For example, skeletal defects are observed in Gaucher's disease, a common lysosomal storage disorder, caused by deficiency in lysosomal glucocerebrosidase (Ayto and Hughes, 2013). Deficiency of ubiquitously expressed protein tyrosine phosphatase, SHP-2, which is an important protein for mediating intracellular signal transduction, leads to severe skeletal abnormalities such as kyphosis and scoliosis in mice (Bauler et. al., 2011). But, the mechanism by which loss of activity of these proteins manifests in skeletal disorders is not known yet. Unlike these mutants where the skeletal deformity manifests since birth, *Asrij* knockout mice exhibit kyphosis only with increasing age, thus, it is more likely to be a secondary effect of *Asrij* knockout.

These studies highlight the importance of endocytosis in the pathogenesis of skeletal abnormalities. Proper functioning of endocytic routes is important for quality control of cellular processes and hence should be tightly regulated. The precise reason for manifestation of skeletal defects upon mutations of these endosomal proteins is not known yet. One possibility could be that tissues such as bone and cartilage are more susceptible to functional alterations of the components of the endosomal machinery and tend to undergo progressive degeneration upon their perturbation.

We also observed defects in the hematopoietic tissue arrangement in *asrij<sup>fl/fl</sup>;Cre* mice. Deficiency of *Asrij* induced hypocellularity of the bone marrow and it is possible that loss of cellularity affects granulopoiesis and megakaryopoiesis, which accounts for the increased production of WBCs and platelets in mutant mice.

Splenomegaly or enlargement of the spleen is the hallmark of various hematological disorders. At necropsy, all 6 months old *asrij<sup>fl/fl</sup>;Cre* mice showed a marked splenomegaly and histological analysis of spleens isolated from aged mice revealed enlarged lymphoid nodules as compared to their wild-type littermates. Lymphoid follicles are circumscribed masses of proliferating lymphocytes and increase in their size suggests increased proliferation of lymphocytes in the *asrij<sup>fl/fl</sup>;Cre* mice.

Perturbation of several proteins participating in normal intracellular signalling is seen to result in splenomegaly. Knockout mouse models of CCAAT/enhancer binding protein (c/EBP alpha), a myeloid specific transcription factor (Porse et. al., 2005); CD40 receptor, an integral membrane protein found on the surface of B-lymphocytes, dendritic cells and hematopoietic progenitor cells (Stunz et. al., 2004); Foxo3, a transcription factor and a critical regulator of oxidative stress (Yalcin et. al., 2010) and dynamin 2, a conserved GTPase that functions in endocytosis and vesicle transport and is required for megakaryocyte maturation and platelet formation (Bender et. al., 2014) exhibit splenomegaly. In hematological disorders, splenomegaly mostly occurs for compensation of ineffective bone marrow hematopoiesis and is thus secondary to bone marrow failure. It is initiated by mobilization of hematopoietic progenitor cells to the spleen for extramedullary hematopoiesis (Sohawon et. al., 2012). Phenotypic characterization of splenocytes isolated from *asrij<sup>fl/fl</sup>;Cre* mice will help provide further evidence for extramedullary hematopoiesis.

In summary, we report a model in which global knockout of *Asrij* from mice results in gross morphological defects in various tissues, and, most strikingly, the development of severe skeletal abnormalities. This model will be of further use in dissecting the role of *Asrij* as a regulator of skeletal morphogenesis and maintenance. Knowledge gained is likely to yield insight into the etiology of skeletal malformations and may also help provide a rational basis for the development of therapies for the prevention and treatment of this condition.

## **Chapter 6: Discussion**

The conservation of various molecular pathways across evolution has aided our understanding of the conserved mechanisms of hematopoiesis in mice. For the past few years, several genetic perturbations associated with human hematological disorders are being studied in mice due to availability of several mutants mimicking such disorders. In this thesis, we report the conserved role of the endocytic protein Asrij in mouse hematopoiesis. We also show that there is a great overlap in the signalling pathways regulated by Asrij in *Drosophila* and mouse.

### **6.1 *Asrij is a conserved endocytic protein***

There have been various reports of transcription factors or receptor molecules involved in signalling that regulate hematopoiesis. However, one of the most remarkable features of Asrij, which sets it apart from other regulators of hematopoiesis, is its cellular location. Data regarding the role of endocytic proteins as hematopoietic regulators is limiting and has not been well explored. To elucidate the conserved functions of *asrij* in hematopoiesis, we undertook a functional analysis of Asrij in mouse and the results obtained highlight that the mechanism of Asrij function has been conserved in evolution.

### **6.2 *Asrij modulates several signalling pathways by virtue of its endocytic location***

Multiple signalling pathways that regulate the establishment and maintenance of blood cells are known; yet mechanisms that facilitate and regulate their cross-talk to maintain homeostasis is not understood. A unified picture of how homeostasis is established by cross-regulation with the help of endocytic molecules such as Asrij will help us understand the



systems biology of the process. It is likely that nodal points of connection exist between different signalling pathways thus enabling spatio-temporal regulation of signalling.

Asrij impinges upon several signalling pathways that govern hematopoiesis, such as, Notch Pathway, ubiquitin-proteasome degradation pathway, JAK/STAT pathway and the Akt pathway, in both *Drosophila* and mouse. It also regulates expression of the COP9 signalosome components.

### **Endosomal inhibition of Notch signalling**

Asrij negatively modulates the Notch pathway by regulating its trafficking thus inhibiting over-proliferation of bone marrow HSCs. The results obtained from cleaved Notch 1 (NICD) immunostaining and immunoblotting experiments indicate that Asrij plays a crucial role in regulating the dynamics of Notch receptor trafficking. Live Notch trafficking assays performed using *Drosophila* Asrij null mutants confirm that loss of this endosomal protein seems to affect the dynamics of Notch receptor internalization, leading to increased entrapment of NICD, thereby affecting crystal cell differentiation (Khadilkar thesis, 2014).

Over-activation of Notch 1 leads to uncontrolled cell proliferation which leads to an increase in the bone marrow stem cell populations, i.e., LT-HSCs and ST-HSCs. The increased HSC population phenotype observed in *asrij<sup>fl/fl</sup>;Cre* mice resembles the phenotype observed in RAG knockout mice overexpressing Notch 1 (Stier et. al., 2002). This confirms that uncontrolled Notch 1 activation leads to increased proliferation of the HSCs, probably by altering the expression of the downstream target genes such as Runx, Hes, c-myc, etc (Refer Figure 6.1).

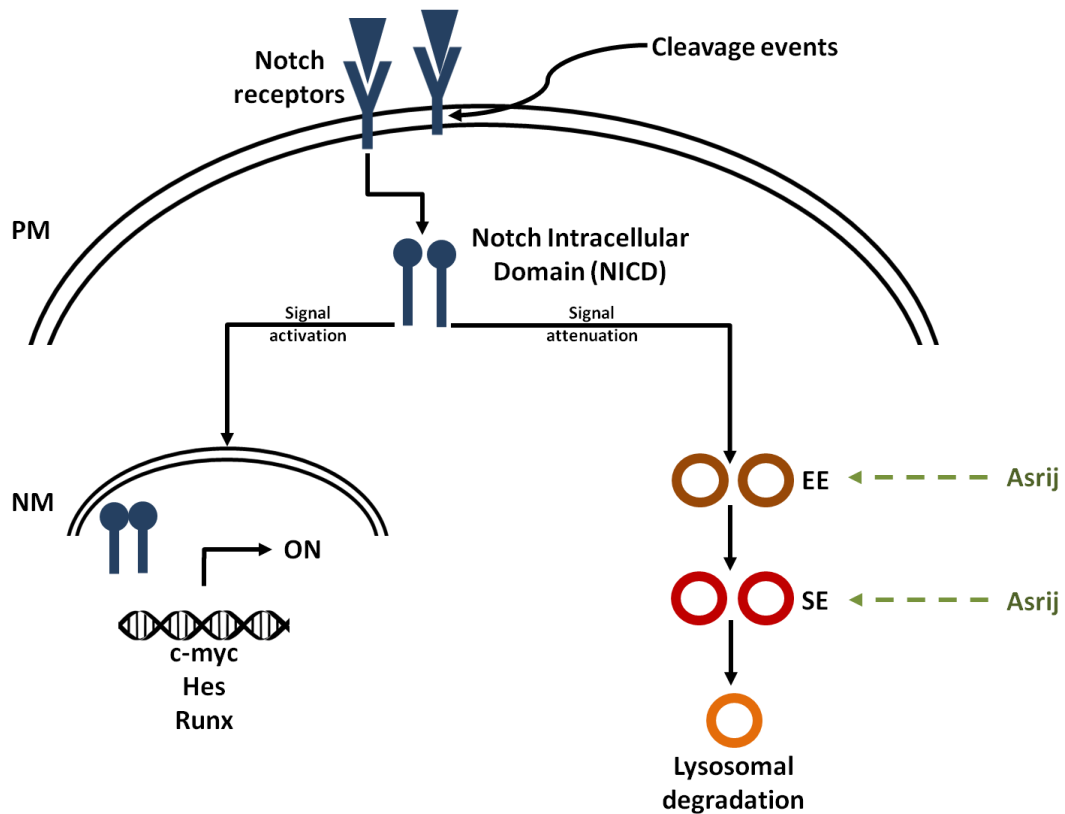

**Figure 6.1: Asrij negatively regulates the Notch pathway.** Asrij depletion might be leading to rapid uptake of Notch intracellular domain. Owing to the altered dynamics of trafficking in the absence of Asrij, these molecules probably get entrapped in the endosomes (EE refers to early endosomes and SE refers to sorting endosomes). Based on the Notch accumulation phenotype, it seems that Asrij regulates cargo sorting and degradation of proteins and receptor molecules for signal attenuation. Dashed green arrows indicate the possible sites of action of Asrij along the endocytic route. PM and NM refer to the plasma membrane and the nuclear membrane, respectively.

### Loss of Asrij leads to increased ubiquitination

Like *Drosophila* Asrij mutants, *asrij<sup>fl/fl</sup>;Cre* mice show ubiquitin accumulation indicating a cargo sorting defect. Based on the increased ubiquitin phenotype observed from our immunostaining and immunoblotting analyses, it is likely that Asrij regulates the cellular degradation machinery.

Proteomics analyses of the genetically modified *Drosophila* lymph glands revealed perturbation of several components of the ESCRT machinery. In addition, several E3 ubiquitin ligases showed altered expression in the Asrij modified lymph glands. Asrij could be an integral part of the ESCRT machinery which needs to be investigated further. Genetic

interaction studies between Asrij and the ESCRT machinery components will help divulge a lot of details about the mode of its action.

### **Endosomal regulation of the COP9 signalosome**

The COP9 signalosome functions to coordinate cellular events occurring between protein ubiquitination and its subsequent degradation (Lingaraju et. al., 2014). X-ray crystallography studies of the COP9 signalosome revealed that COPS5 and COPS6 are topologically knotted. These two subunits share a great deal of similarities in their sequence and structural organization and are the only two to contain MPR1/PAD1 (MPN) domains (Tran et. al., 2003; Ambroggio et. al., 2004; Zhang et. al., 2012; Echaliier et. al., 2013).

Global gene expression analysis of Asrij-modulated mESC lines (A. Sinha thesis, 2013) and proteomics of genetically modified lymph glands revealed perturbation of several components of the COP9 signalosome. Biochemical analyses using *asrij<sup>fl/fl</sup>;Cre* mice tissues confirmed that Asrij differentially regulates the expression of components of the COP9 signalosome. It negatively regulates the expression of COPS5 whereas positively regulates the expression of COPS6 (Refer Figure 6.2). Whether Asrij physically interacts with any of the COP9 signalosome components needs to be investigated.

COPS5 and COPS6 are potent negative regulators of the tumor suppressor p53 (Zhang et. al., 2008; Zhao et. al., 2011). COPS5 interacts with p53 and mediates its degradation. Mechanistic studies have revealed that COPS6 expression leads to the stabilization of several E3 ubiquitin ligases such as COPS1 and MDM2 (mouse double minute 2) by reducing their self-ubiquitination. COPS6 expression stabilizes COPS1, which acts as an E3 ubiquitin ligase for 14-3-3 $\sigma$ , by preventing its auto-ubiquitination, thereby enhancing its stability (Choi et. al., 2011). It also stabilizes MDM2, another E3 ubiquitin ligase, specific for p53 (Xue et. al., 2012).

This is the first report of a protein differentially regulating the expression levels of the components of the COPS5-COPS6 heterodimer. It will be interesting to check the cumulative effect of COPS5 up-regulation and COPS6 down-regulation on the stability of p53.

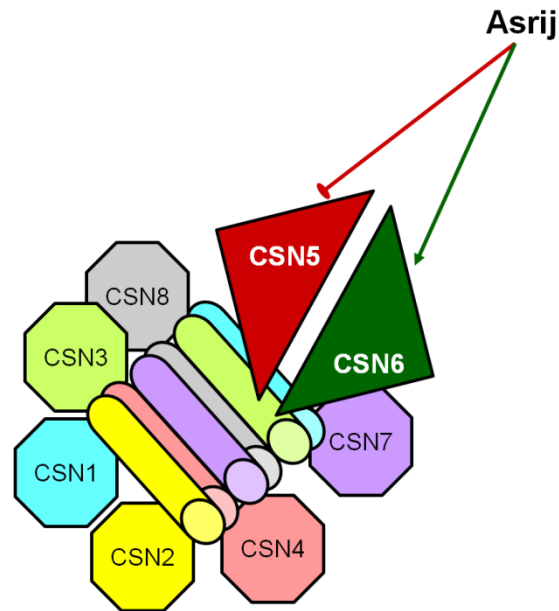
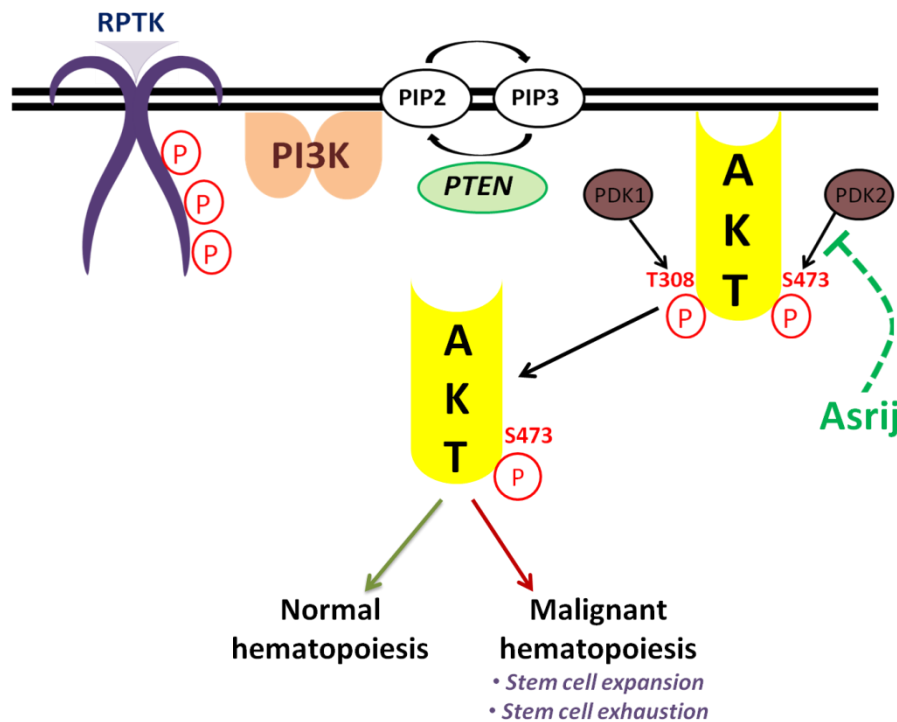

**Figure 6.2: Asrij regulates the expression levels of the COP9 signalosome.** Schematic representing the COP9 signalosome. The expression of COPS5 and COPS6 components are Asrij dependent. Asrij could physically interact with the COPS5-COPS6 heterodimer to regulate various decisions made at the COP9 signalosome.

### Endosomal inhibition of the PI3K/Akt pathway

The PI3K/Akt pathway not only promotes growth and survival in response to extracellular signals (Song et. al., 2005) but also plays an important role in normal as well as malignant hematopoiesis (Kharas et. al., 2010). Akt is found to be constitutively active in most of the patients suffering from acute myeloid leukemia (AML) and increased phosphorylation of Akt at residue serine 473 induces leukemia (Xu et. al., 2003; Min et. al., 2003; Grandage et. al., 2005; Park et. al., 2005). Western blotting analysis across different ages of *asrij<sup>fl/fl</sup>; Cre* mice show increased Akt phosphorylation at residue serine 473. This strongly indicates that Asrij negatively regulates Akt (S473) phosphorylation and loss of Asrij affects hematopoiesis in mice

(Refer Figure 6.3). Mechanistic details regarding how increased Akt activation directly contributes to aberrant hematopoiesis in *asrij<sup>fl/fl</sup>*; *Cre* mice need to be investigated further.



**Figure 6.3: Asrij negatively regulates the PI3K/Akt pathway.** The PI3K/Akt pathway plays a critical role in regulating cell growth, survival and proliferation. Asrij regulates the Akt pathway by controlling phosphorylation of Akt at serine 473. Loss of Asrij leads to increase levels of activated Akt (dashed green arrow), thus, Asrij is a negative regulator of the PI3K/Akt pathway. Activated Akt is required for processes underlying normal hematopoiesis (green solid arrow), but its short term induction or constitutively high expression (red solid arrow) leads to stem cell expansion or exhaustion, respectively.

In addition, Akt signalling is an important positive regulator of COPS6. Activated Akt phosphorylates COPS6 at Serine 60 and reduces the rate of its auto-ubiquitination, thereby stabilizing it (Xue et. al., 2012). Interestingly, in *asrij<sup>fl/fl</sup>*; *Cre* mice we see increased levels of activated Akt but the decreased levels of total COPS6, suggesting that Asrij plays an important role in regulating the cross-talk between Akt and COPS6 (Refer Figure 6.4). Further, the outcome of the AKT- COPS6 interaction is likely to be context dependent.

## Endosomal regulation of the JAK/STAT pathway

In *Drosophila*, Asrij plays an important role in activating the STAT3 homolog, STAT92e, for maintenance of prohemocytes. In addition, analysis of Asrij modulated mouse embryonic stem cell lines revealed that Asrij maintains pluripotency by promoting STAT3 activation (Sinha et. al., 2013). Deficiency of Asrij in mice affects the activated STAT3 levels but not total STAT3 levels in vascularised tissues. Taken together, Asrij has a conserved role in regulating the JAK/STAT pathway (Refer Figure 6.4).

In light of the hematopoietic impairment in *asrij<sup>fl/fl</sup>;Cre* mice, it is possible that inhibition of activated STAT3 signalling in these mice functions to neutralize the leukemia-induced immunosuppressive microenvironment, thereby contributing to anti-tumor immunity. These data suggest the need for more detailed studies on the role of Asrij in regulating STAT3 mediated signalling in the mouse bone marrow hematopoietic compartment.

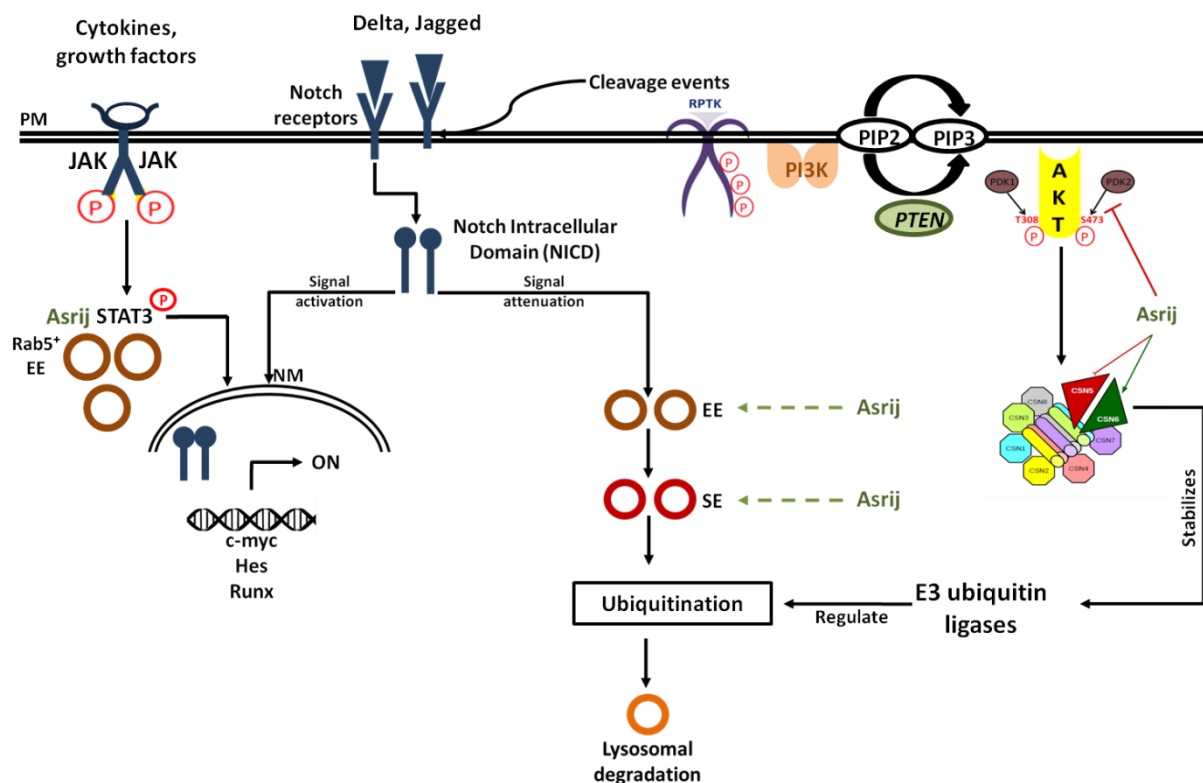

**Figure 6.4: Asrij regulates signals originating from several pathways.** Asrij positively regulates STAT3 activation on Rab5-positive early endosomes (EE); thereby modulating the JAK/STAT pathway. It negatively regulates the Notch pathway and keeps a check on the levels of activated Akt (phosphorylated at Serine 473).

Besides, it also regulates components of the COP9 signalosome, which act at the interface of signal transduction and ubiquitin proteasome degradation. It negatively regulates expression of COPS5 and positively regulates expression of COPS6. Reduced levels of COPS6 lead to destabilization of ubiquitin ligases which in turn affects ubiquitination. Asrij possibly integrates signals originating at different cellular locations from various pathways to maintain blood cell homeostasis.

Thus, Asrij brings about differential modulation of several signalling pathways for maintenance of hematopoiesis in mice. It acts at multiple locations along different endocytic routes and seems to be the nodal connection mediating cross-talk among several pathways such as Notch Pathway, ubiquitin-proteasome degradation pathway, PI3K/Akt pathway, JAK/STAT pathway and components of the COP9 signalosome. This thesis highlights the role of the endosomal protein Asrij as a key regulator of cellular signalling processes that maintain hematopoiesis.

### ***6.3 Asrij is a key regulator of mouse hematopoiesis***

Endocytic protein Asrij which is expressed in a majority of the CD45<sup>+</sup> bone marrow cells has a key role in controlling homeostasis of the bone marrow compartment and the circulating blood cells. Asrij deficiency leads to increased proliferation of LT-HSCs during late developmental stages. This phenotype is quite comparable to the already reported mutants for Notch (Stier et. al., 2002), STAT3 (Mantel et. al., 2012) and dynamin 2 (Bender et. al., 2014). This suggests a possible role for Asrij as a negative regulator of factors that promote HSC proliferation, which needs to be investigated in further detail. Higher mitotic activity of the HSCs in absence of Asrij could be leading to increased HSC counts in the bone marrow of the mutant mice. We hypothesize that Asrij interacts with components of the osteoblastic and vascular niches to regulate proliferation of HSCs in the bone marrow microenvironment.

Increasing evidence suggests that the repopulating ability of HSCs is directly related to their proliferative capacity (Ingmar et. al., 2009). It is not known if bone marrow cells lacking

Asrij exhibit any functional impairment. Bone marrow transplantation assays using *asrij<sup>fl/fl</sup>;Cre* mice will help analyze if Asrij deficient bone marrow cells are able to reconstitute the hematopoietic system of lethally irradiated mice. Apart from testing the engrafting ability of *asrij<sup>fl/fl</sup>;Cre* bone marrow cells, it will be interesting to investigate the recovery rate of the hematopoietic system of *asrij<sup>fl/fl</sup>;Cre* mice upon administration of sub-lethal doses of gamma radiation or chemically induced hematopoietic stress. Splenomegaly is common to presentation in *asrij<sup>fl/fl</sup>;Cre* mice. *In vitro* hematopoietic assays such as Cobblestone Area Forming Cell (CBAC) assay using splenocytes will help analyze whether increase in the spleen size is the outcome of extramedullary hematopoiesis in *asrij<sup>fl/fl</sup>;Cre* mice.

#### **6.4 *asrij<sup>fl/fl</sup>;Cre* mice as leukemia models**

*Ociad1* has been implicated in several cancers including hematological malignancies (Arai et. al., 1987; Shen et. al., 2002; Usary et. al., 2004; Nigrovic et.al., 2008). Asrij depletion in mice induces aberrant hematopoietic phenotypes; the bone marrow hematopoietic compartment is affected due to which blood cell homeostasis is disturbed. Loss of Asrij leads to increased RBC, WBC and platelet counts in mice, mimicking the disease situation where there is increased proliferation of blood cells from the myeloid lineage, i.e. myeloproliferative disorders.

There are not many mouse models available for studying myeloproliferative disorders (MPDs). To mention a few of them that have helped understand the molecular pathogenesis underlying MPDs so far are - mouse model overexpressing transcription factor NF-E2 (Kaufmann et. al., 2012), mouse model bearing JAK2V617F mutation (Li et. al., 2011), Ts65Dn mouse model of Down Syndrome (Kirsammer et. al., 2008), etc.



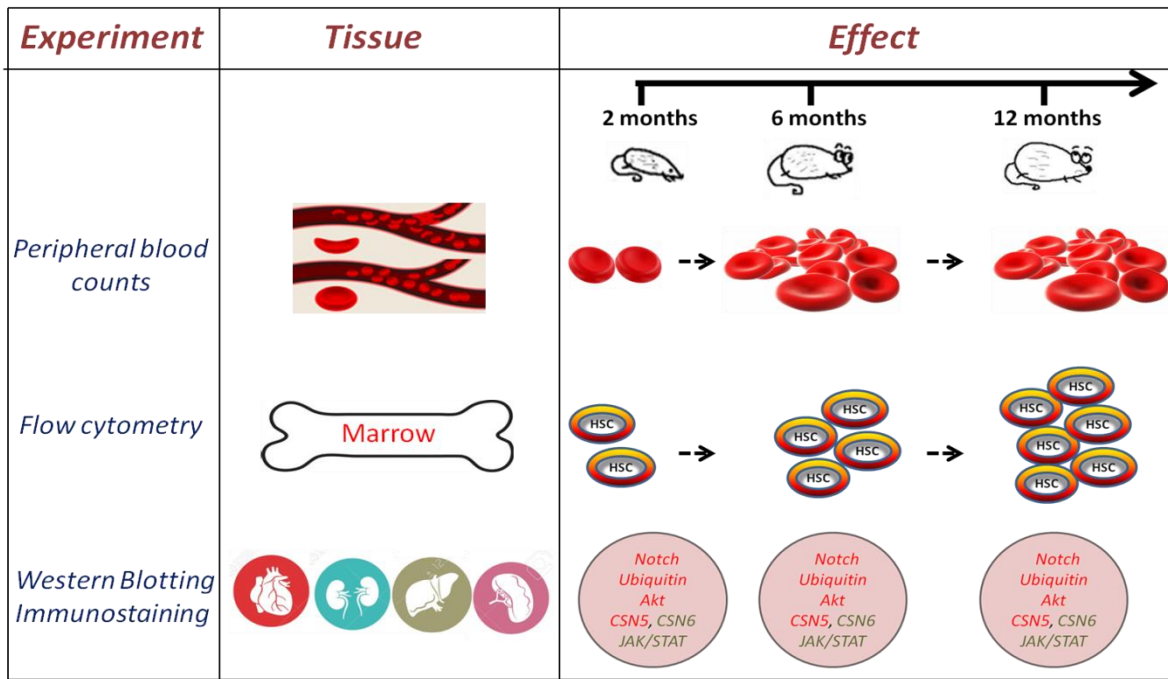

**Figure 6.5: Hematopoietic and signalling defects in *Asrij* knockout mice.** Loss of *Asrij* leads to an age-dependent disease progression in mice. *Asrij* knockout mice gradually exhibit increased blood cell and stem cell counts and mimic the features of myeloproliferative disorders in humans.

Given that there is a paucity of models available for studying myeloproliferative disorders, *Asrij* knockout mice could be used to improve our understanding of the human hematological malignancies.

Multiple signalling pathways such as Notch, ubiquitin proteasome, PI3K/Akt, JAK/STAT pathway along with components of the COP9 signalosome have been implicated in myeloproliferative disorders. Perturbation of all these signalling modules in *asrij<sup>fl/fl</sup>;Cre* mice strongly indicates that it is a key regulator of hematopoiesis. This seems to be possible mainly because of the endocytic location of *Asrij* that enables it to integrate and coordinate the incoming cellular inputs. Since *Asrij* mutant mice display leukemic phenotypes, these could serve to be valuable models to screen for genetic and small molecule modulators which can suppress the leukemic phenotype. The candidate molecules identified, can prove to be effective for treatment of human hematological malignancies.

## References:

1. Nichols, J. and A. Smith, *The origin and identity of embryonic stem cells*. Development, 2011. **138**(1): p. 3-8.
2. Snippert, H.J. and H. Clevers, *Tracking adult stem cells*. EMBO Rep, 2011. **12**(2): p. 113-22.
3. Korbiling, M. and Z. Estrov, *Adult stem cells for tissue repair - a new therapeutic concept?* N Engl J Med, 2003. **349**(6): p. 570-82.
4. Scadden, D. and A. Srivastava, *Advancing stem cell biology toward stem cell therapeutics*. Cell Stem Cell, 2012. **10**(2): p. 149-50.
5. Tam, W.L., et al., *T-cell factor 3 regulates embryonic stem cell pluripotency and self-renewal by the transcriptional control of multiple lineage pathways*. Stem Cells, 2008. **26**(8): p. 2019-31.
6. Fong, Y.W., et al., *Transcriptional regulation by coactivators in embryonic stem cells*. Trends Cell Biol, 2012. **22**(6): p. 292-8.
7. Sigismund, S., et al., *Endocytosis and signaling: cell logistics shape the eukaryotic cell plan*. Physiol Rev, 2012. **92**(1): p. 273-366.
8. Benmerah, A., *Endocytosis: signaling from endocytic membranes to the nucleus*. Curr Biol, 2004. **14**(8): p. R314-6.
9. Sorkin, A. and M. von Zastrow, *Endocytosis and signalling: intertwining molecular networks*. Nat Rev Mol Cell Biol, 2009. **10**(9): p. 609-22.
10. Bank, A., *Hematopoietic stem cell gene therapy: selecting only the best*. J Clin Invest, 2003. **112**(10): p. 1478-80.
11. Tripura, C. and G. Pande, *Applications of human hematopoietic stem cells isolated and expanded from different tissues in regenerative medicine*. Regen Med, 2013. **8**(6): p. 783-95.
12. Felfly, H. and G.G. Haddad, *Hematopoietic stem cells: potential new applications for translational medicine*. J Stem Cells, 2014. **9**(3): p. 163-97.
13. Shizuru, J.A., et al., *Transplantation of purified hematopoietic stem cells: requirements for overcoming the barriers of allogeneic engraftment*. Biol Blood Marrow Transplant, 1996. **2**(1): p. 3-14.
14. Quinones, R.R., *Hematopoietic engraftment and graft failure after bone marrow transplantation*. Am J Pediatr Hematol Oncol, 1993. **15**(1): p. 3-17.
15. Locatelli, F., et al., *Outcome of children with high-risk acute myeloid leukemia given autologous or allogeneic hematopoietic cell transplantation in the aieop AML-2002/01 study*. Bone Marrow Transplant, 2015. **50**(2): p. 181-8.
16. Warr, M.R., E.M. Pietras, and E. Passegue, *Mechanisms controlling hematopoietic stem cell functions during normal hematopoiesis and hematological malignancies*. Wiley Interdiscip Rev Syst Biol Med, 2011. **3**(6): p. 681-701.
17. Chotinantakul, K. and W. Leeansaksiri, *Hematopoietic stem cell development, niches, and signaling pathways*. Bone Marrow Res, 2012. **2012**: p. 270425.
18. Spangrude, G.J., S. Heimfeld, and I.L. Weissman, *Purification and characterization of mouse hematopoietic stem cells*. Science, 1988. **241**(4861): p. 58-62.
19. Weissman, I.L., *Stem cells: units of development, units of regeneration, and units in evolution*. Cell, 2000. **100**(1): p. 157-68.
20. Evans, C.J., V. Hartenstein, and U. Banerjee, *Thicker than blood: conserved mechanisms in Drosophila and vertebrate hematopoiesis*. Dev Cell, 2003. **5**(5): p. 673-90.
21. Ploemacher, R.E., *Stem cells: characterization and measurement*. Baillieres Clin Haematol, 1997. **10**(3): p. 429-44.
22. Domen, J. and I.L. Weissman, *Self-renewal, differentiation or death: regulation and manipulation of hematopoietic stem cell fate*. Mol Med Today, 1999. **5**(5): p. 201-8.
23. Snodgrass, D.R., et al., *Identification of four VP4 serological types (P serotypes) of bovine rotavirus using viral reassortants*. J Gen Virol, 1992. **73** ( Pt 9): p. 2319-25.

24. Beug, H., et al., *Avian hematopoietic cell culture: in vitro model systems to study oncogenic transformation of hematopoietic cells*. *Methods Enzymol*, 1995. **254**: p. 41-76.
25. Drexler, H.G. and Y. Matsuo, *Malignant hematopoietic cell lines: in vitro models for the study of multiple myeloma and plasma cell leukemia*. *Leuk Res*, 2000. **24**(8): p. 681-703.
26. Torisawa, Y.S., et al., *Bone marrow-on-a-chip replicates hematopoietic niche physiology in vitro*. *Nat Methods*, 2014. **11**(6): p. 663-9.
27. Bhatt, P.K. and W.S. Neckameyer, *Functional analysis of the larval feeding circuit in Drosophila*. *J Vis Exp*, 2013(81): p. e51062.
28. Makhijani, K., et al., *The peripheral nervous system supports blood cell homing and survival in the Drosophila larva*. *Development*, 2011. **138**(24): p. 5379-91.
29. Crozatier, M. and A. Vincent, *Drosophila: a model for studying genetic and molecular aspects of haematopoiesis and associated leukaemias*. *Dis Model Mech*, 2011. **4**(4): p. 439-45.
30. Huang, H.T. and L.I. Zon, *Regulation of stem cells in the zebra fish hematopoietic system*. *Cold Spring Harb Symp Quant Biol*, 2008. **73**: p. 111-8.
31. Chen, A.T. and L.I. Zon, *Zebrafish blood stem cells*. *J Cell Biochem*, 2009. **108**(1): p. 35-42.
32. Paik, E.J. and L.I. Zon, *Hematopoietic development in the zebrafish*. *Int J Dev Biol*, 2010. **54**(6-7): p. 1127-37.
33. Davidson, A.J. and L.I. Zon, *The 'definitive' (and 'primitive') guide to zebrafish hematopoiesis*. *Oncogene*, 2004. **23**(43): p. 7233-46.
34. de Jong, J.L. and L.I. Zon, *Use of the zebrafish system to study primitive and definitive hematopoiesis*. *Annu Rev Genet*, 2005. **39**: p. 481-501.
35. Lieschke, G.J. and P.D. Currie, *Animal models of human disease: zebrafish swim into view*. *Nat Rev Genet*, 2007. **8**(5): p. 353-67.
36. Pietras, E.M., M.R. Warr, and E. Passegue, *Cell cycle regulation in hematopoietic stem cells*. *J Cell Biol*, 2011. **195**(5): p. 709-20.
37. Luis, T.C., et al., *Wnt signaling strength regulates normal hematopoiesis and its deregulation is involved in leukemia development*. *Leukemia*, 2012. **26**(3): p. 414-21.
38. Morrison, S.J. and D.T. Scadden, *The bone marrow niche for haematopoietic stem cells*. *Nature*, 2014. **505**(7483): p. 327-34.
39. Yin, T. and L. Li, *The stem cell niches in bone*. *J Clin Invest*, 2006. **116**(5): p. 1195-201.
40. Guerrouahen, B.S., I. Al-Hijji, and A.R. Tabrizi, *Osteoblastic and vascular endothelial niches, their control on normal hematopoietic stem cells, and their consequences on the development of leukemia*. *Stem Cells Int*, 2011. **2011**: p. 375857.
41. Jenkins, M.C., E.B. Allibone, and P.J. Berry, *Neuroglial tissue in partially cystic Wilms' tumour*. *Histopathology*, 1991. **18**(4): p. 309-13.
42. Bigas, A. and L. Espinosa, *Hematopoietic stem cells: to be or Notch to be*. *Blood*, 2012. **119**(14): p. 3226-35.
43. Zhou, X.L. and J.C. Liu, *Role of Notch signaling in the mammalian heart*. *Braz J Med Biol Res*, 2014. **47**(1): p. 1-10.
44. Lobry, C., et al., *Notch pathway activation targets AML-initiating cell homeostasis and differentiation*. *J Exp Med*, 2013. **210**(2): p. 301-19.
45. Yu, X., et al., *Notch signaling activation in human embryonic stem cells is required for embryonic, but not trophoblastic, lineage commitment*. *Cell Stem Cell*, 2008. **2**(5): p. 461-71.
46. Schwanbeck, R. and U. Just, *The Notch signaling pathway in hematopoiesis and hematologic malignancies*. *Haematologica*, 2011. **96**(12): p. 1735-7.
47. Hasserjian, R.P., et al., *Modulated expression of notch1 during thymocyte development*. *Blood*, 1996. **88**(3): p. 970-6.
48. Van de Walle, I., et al., *Specific Notch receptor-ligand interactions control human TCR-alpha/beta/gammadelta development by inducing differential Notch signal strength*. *J Exp Med*, 2013. **210**(4): p. 683-97.

49. Yin, D.D., et al., *Notch signaling inhibits the growth of the human chronic myeloid leukemia cell line K562*. *Leuk Res*, 2009. **33**(1): p. 109-14.
50. Sengupta, A., et al., *Deregulation and cross talk among Sonic hedgehog, Wnt, Hox and Notch signaling in chronic myeloid leukemia progression*. *Leukemia*, 2007. **21**(5): p. 949-55.
51. Aster, J.C., S.C. Blacklow, and W.S. Pear, *Notch signalling in T-cell lymphoblastic leukaemia/lymphoma and other haematological malignancies*. *J Pathol*, 2011. **223**(2): p. 262-73.
52. Klinakis, A., et al., *A novel tumour-suppressor function for the Notch pathway in myeloid leukaemia*. *Nature*, 2011. **473**(7346): p. 230-3.
53. O'Shea, J.J., et al., *The JAK-STAT pathway: impact on human disease and therapeutic intervention*. *Annu Rev Med*, 2015. **66**: p. 311-28.
54. Rawlings, J.S., K.M. Rosler, and D.A. Harrison, *The JAK/STAT signaling pathway*. *J Cell Sci*, 2004. **117**(Pt 8): p. 1281-3.
55. Levy, D.E. and J.E. Darnell, Jr., *Stats: transcriptional control and biological impact*. *Nat Rev Mol Cell Biol*, 2002. **3**(9): p. 651-62.
56. Ward, A.C., I. Touw, and A. Yoshimura, *The Jak-Stat pathway in normal and perturbed hematopoiesis*. *Blood*, 2000. **95**(1): p. 19-29.
57. Kharas, M.G. and K. Gritsman, *Akt: a double-edged sword for hematopoietic stem cells*. *Cell Cycle*, 2010. **9**(7): p. 1223-4.
58. Strikoudis, A., M. Guillaumot, and I. Aifantis, *Regulation of stem cell function by protein ubiquitylation*. *EMBO Rep*, 2014. **15**(4): p. 365-82.
59. Bech-Otschir, D., M. Seeger, and W. Dubiel, *The COP9 signalosome: at the interface between signal transduction and ubiquitin-dependent proteolysis*. *J Cell Sci*, 2002. **115**(Pt 3): p. 467-73.
60. Fortunel, N.O., A. Hatzfeld, and J.A. Hatzfeld, *Transforming growth factor-beta: pleiotropic role in the regulation of hematopoiesis*. *Blood*, 2000. **96**(6): p. 2022-36.
61. Larsson, J. and S. Karlsson, *The role of Smad signaling in hematopoiesis*. *Oncogene*, 2005. **24**(37): p. 5676-92.
62. Larsson, J., et al., *TGF-beta signaling-deficient hematopoietic stem cells have normal self-renewal and regenerative ability in vivo despite increased proliferative capacity in vitro*. *Blood*, 2003. **102**(9): p. 3129-35.
63. Soderberg, S.S., G. Karlsson, and S. Karlsson, *Complex and context dependent regulation of hematopoiesis by TGF-beta superfamily signaling*. *Ann N Y Acad Sci*, 2009. **1176**: p. 55-69.
64. Kim, S.J. and J. Letterio, *Transforming growth factor-beta signaling in normal and malignant hematopoiesis*. *Leukemia*, 2003. **17**(9): p. 1731-7.
65. Burk, U., et al., *A reciprocal repression between ZEB1 and members of the miR-200 family promotes EMT and invasion in cancer cells*. *EMBO Rep*, 2008. **9**(6): p. 582-9.
66. Caro, I. and J.A. Low, *The role of the hedgehog signaling pathway in the development of basal cell carcinoma and opportunities for treatment*. *Clin Cancer Res*, 2010. **16**(13): p. 3335-9.
67. Varjosalo, M. and J. Taipale, *Hedgehog: functions and mechanisms*. *Genes Dev*, 2008. **22**(18): p. 2454-72.
68. Tsonis, P.A., et al., *A novel role of the hedgehog pathway in lens regeneration*. *Dev Biol*, 2004. **267**(2): p. 450-61.
69. Gupta, S., N. Takebe, and P. Lorusso, *Targeting the Hedgehog pathway in cancer*. *Ther Adv Med Oncol*, 2010. **2**(4): p. 237-50.
70. Franco, H.L. and H.H. Yao, *Sex and hedgehog: roles of genes in the hedgehog signaling pathway in mammalian sexual differentiation*. *Chromosome Res*, 2012. **20**(1): p. 247-58.
71. Xie, J., *Implications of hedgehog signaling antagonists for cancer therapy*. *Acta Biochim Biophys Sin (Shanghai)*, 2008. **40**(7): p. 670-80.
72. Campbell, V. and M. Copland, *Hedgehog signaling in cancer stem cells: a focus on hematological cancers*. *Stem Cells Cloning*, 2015. **8**: p. 27-38.

73. Lento, W., et al., *Loss of beta-catenin triggers oxidative stress and impairs hematopoietic regeneration*. Genes Dev, 2014. **28**(9): p. 995-1004.
74. Luis, T.C., et al., *Canonical wnt signaling regulates hematopoiesis in a dosage-dependent fashion*. Cell Stem Cell, 2011. **9**(4): p. 345-56.
75. Lento, W., et al., *Wnt signaling in normal and malignant hematopoiesis*. Cold Spring Harb Perspect Biol, 2013. **5**(2).
76. Jamieson, C.H., I.L. Weissman, and E. Passegue, *Chronic versus acute myelogenous leukemia: a question of self-renewal*. Cancer Cell, 2004. **6**(6): p. 531-3.
77. Marinaccio, C., et al., *Insights in Hodgkin Lymphoma angiogenesis*. Leuk Res, 2014. **38**(8): p. 857-61.
78. Park, Y., et al., *MethylSig: a whole genome DNA methylation analysis pipeline*. Bioinformatics, 2014. **30**(17): p. 2414-22.
79. Platta, H.W. and H. Stenmark, *Endocytosis and signaling*. Curr Opin Cell Biol, 2011. **23**(4): p. 393-403.
80. Mayor, S. and R.E. Pagano, *Pathways of clathrin-independent endocytosis*. Nat Rev Mol Cell Biol, 2007. **8**(8): p. 603-12.
81. Doherty, G.J. and H.T. McMahon, *Mechanisms of endocytosis*. Annu Rev Biochem, 2009. **78**: p. 857-902.
82. Pawson, T., *Dynamic control of signaling by modular adaptor proteins*. Curr Opin Cell Biol, 2007. **19**(2): p. 112-6.
83. Khadilkar, R.J., et al., *ARF1-GTP regulates Asrij to provide endocytic control of Drosophila blood cell homeostasis*. Proc Natl Acad Sci U S A, 2014. **111**(13): p. 4898-903.
84. Kulkarni, V., et al., *Asrij maintains the stem cell niche and controls differentiation during Drosophila lymph gland hematopoiesis*. PLoS One, 2011. **6**(11): p. e27667.
85. Sinha, A., et al., *Conserved regulation of the Jak/STAT pathway by the endosomal protein asrij maintains stem cell potency*. Cell Rep, 2013. **4**(4): p. 649-58.
86. Mukhopadhyay, A., D. Das, and M.S. Inamdar, *Embryonic stem cell and tissue-specific expression of a novel conserved gene, asrij*. Dev Dyn, 2003. **227**(4): p. 578-86.
87. Inamdar, M.S., *Drosophila asrij is expressed in pole cells, trachea and hemocytes*. Dev Genes Evol, 2003. **213**(3): p. 134-7.
88. Giot, L., et al., *A protein interaction map of Drosophila melanogaster*. Science, 2003. **302**(5651): p. 1727-36.
89. Dobrowolski, R. and E.M. De Robertis, *Endocytic control of growth factor signalling: multivesicular bodies as signalling organelles*. Nat Rev Mol Cell Biol, 2012. **13**(1): p. 53-60.
90. Brumby, A.M. and H.E. Richardson, *Using Drosophila melanogaster to map human cancer pathways*. Nat Rev Cancer, 2005. **5**(8): p. 626-39.
91. Schlondorff, J., *Nephrin AKTs on actin: The slit diaphragm-actin cytoskeleton signaling network expands*. Kidney Int, 2008. **73**(5): p. 524-6.
92. Satoh, C., et al., *Role of endogenous angiotensin II in the increased expression of growth factors in vascular smooth muscle cells from spontaneously hypertensive rats*. J Cardiovasc Pharmacol, 2001. **37**(1): p. 108-18.
93. Ayto, R. and D.A. Hughes, *Gaucher disease and myeloma*. Crit Rev Oncog, 2013. **18**(3): p. 247-68.
94. Bauler, T.J., et al., *Development of severe skeletal defects in induced SHP-2-deficient adult mice: a model of skeletal malformation in humans with SHP-2 mutations*. Dis Model Mech, 2011. **4**(2): p. 228-39.
95. Nemazanyy, I., et al., *Defects of Vps15 in skeletal muscles lead to autophagic vacuolar myopathy and lysosomal disease*. EMBO Mol Med, 2013. **5**(6): p. 870-90.
96. George, B., et al., *Myogenesis defect due to Toca-1 knockdown can be suppressed by expression of N-WASP*. Biochim Biophys Acta, 2014. **1843**(9): p. 1930-41.

97. Vaccari, T., et al., *Endosomal entry regulates Notch receptor activation in Drosophila melanogaster*. J Cell Biol, 2008. **180**(4): p. 755-62.
98. Oron, E., et al., *COP9 signalosome subunits 4 and 5 regulate multiple pleiotropic pathways in Drosophila melanogaster*. Development, 2002. **129**(19): p. 4399-409.
99. Wei, N., G. Serino, and X.W. Deng, *The COP9 signalosome: more than a protease*. Trends Biochem Sci, 2008. **33**(12): p. 592-600.
100. Reavie, L., et al., *Regulation of hematopoietic stem cell differentiation by a single ubiquitin ligase-substrate complex*. Nat Immunol, 2010. **11**(3): p. 207-15.
101. Raiborg, C. and H. Stenmark, *The ESCRT machinery in endosomal sorting of ubiquitylated membrane proteins*. Nature, 2009. **458**(7237): p. 445-52.
102. Pan, L., et al., *Protein competition switches the function of COP9 from self-renewal to differentiation*. Nature, 2014. **514**(7521): p. 233-6.
103. Tian, L., et al., *Essential roles of Jab1 in cell survival, spontaneous DNA damage and DNA repair*. Oncogene, 2010. **29**(46): p. 6125-37.
104. Mori, M., et al., *Stable form of JAB1 enhances proliferation and maintenance of hematopoietic progenitors*. J Biol Chem, 2008. **283**(43): p. 29011-21.
105. Tomoda, K., et al., *The Jab1/COP9 signalosome subcomplex is a downstream mediator of Bcr-Abl kinase activity and facilitates cell-cycle progression*. Blood, 2005. **105**(2): p. 775-83.
106. Tse, W.K., et al., *The deubiquitylating enzyme Cops6 regulates different developmental processes during early zebrafish embryogenesis*. Int J Dev Biol, 2011. **55**(1): p. 19-24.
107. Manning, B.D. and L.C. Cantley, *AKT/PKB signaling: navigating downstream*. Cell, 2007. **129**(7): p. 1261-74.
108. Samuels, Y., et al., *High frequency of mutations of the PIK3CA gene in human cancers*. Science, 2004. **304**(5670): p. 554.
109. Yilmaz, O.H., et al., *Pten dependence distinguishes haematopoietic stem cells from leukaemia-initiating cells*. Nature, 2006. **441**(7092): p. 475-82.
110. Tesio, M., et al., *Pten loss in the bone marrow leads to G-CSF-mediated HSC mobilization*. J Exp Med, 2013. **210**(11): p. 2337-49.
111. Sussman, M., *"AKT"ing lessons for stem cells: regulation of cardiac myocyte and progenitor cell proliferation*. Trends Cardiovasc Med, 2007. **17**(7): p. 235-40.
112. Mantel, C., et al., *Mouse hematopoietic cell-targeted STAT3 deletion: stem/progenitor cell defects, mitochondrial dysfunction, ROS overproduction, and a rapid aging-like phenotype*. Blood, 2012. **120**(13): p. 2589-99.
113. Vainchenker, W. and S.N. Constantinescu, *JAK/STAT signaling in hematological malignancies*. Oncogene, 2013. **32**(21): p. 2601-13.
114. Kortylewski, M., et al., *Inhibiting Stat3 signaling in the hematopoietic system elicits multicomponent antitumor immunity*. Nat Med, 2005. **11**(12): p. 1314-21.
115. Sehgal, P.B., *Paradigm shifts in the cell biology of STAT signaling*. Semin Cell Dev Biol, 2008. **19**(4): p. 329-40.
116. Tefferi, A. and J.W. Vardiman, *Classification and diagnosis of myeloproliferative neoplasms: the 2008 World Health Organization criteria and point-of-care diagnostic algorithms*. Leukemia, 2008. **22**(1): p. 14-22.
117. Lee, D., et al., *Transmembrane Inhibitor of RICTOR/mTORC2 in Hematopoietic Progenitors*. Stem Cell Reports, 2014. **3**(5): p. 832-40.
118. Weiss, L. and U. Geduldig, *Barrier cells: stromal regulation of hematopoiesis and blood cell release in normal and stressed murine bone marrow*. Blood, 1991. **78**(4): p. 975-90.
119. Mizuno, E., et al., *STAM proteins bind ubiquitinated proteins on the early endosome via the VHS domain and ubiquitin-interacting motif*. Mol Biol Cell, 2003. **14**(9): p. 3675-89.
120. Cully, M., et al., *grb2 heterozygosity rescues embryonic lethality but not tumorigenesis in pten+/- mice*. Proc Natl Acad Sci U S A, 2004. **101**(43): p. 15358-63.

121. Giubellino, A., T.R. Burke, Jr., and D.P. Bottaro, *Grb2 signaling in cell motility and cancer*. Expert Opin Ther Targets, 2008. **12**(8): p. 1021-33.
122. Gillis, L.C., et al., *Gads (Grb2-related adaptor downstream of Shc) is required for BCR-ABL-mediated lymphoid leukemia*. Leukemia, 2013. **27**(8): p. 1666-76.
123. Stier, S., et al., *Notch1 activation increases hematopoietic stem cell self-renewal in vivo and favors lymphoid over myeloid lineage outcome*. Blood, 2002. **99**(7): p. 2369-78.
124. Lingaraju, G.M., et al., *Crystal structure of the human COP9 signalosome*. Nature, 2014. **512**(7513): p. 161-5.
125. Echaliier, A., et al., *Insights into the regulation of the human COP9 signalosome catalytic subunit, CSN5/Jab1*. Proc Natl Acad Sci U S A, 2013. **110**(4): p. 1273-8.
126. Salmena, L. and R. Hakem, *From photomorphogenesis to cancer: a CSN journey*. Cell Cycle, 2013. **12**(2): p. 205-6.
127. Choi, H.H., et al., *COP9 signalosome subunit 6 stabilizes COP1, which functions as an E3 ubiquitin ligase for 14-3-3sigma*. Oncogene, 2011. **30**(48): p. 4791-801.
128. Song, G., G. Ouyang, and S. Bao, *The activation of Akt/PKB signaling pathway and cell survival*. J Cell Mol Med, 2005. **9**(1): p. 59-71.
129. Zhang, X.C., et al., *Roles for CSN5 in control of p53/MDM2 activities*. J Cell Biochem, 2008. **103**(4): p. 1219-30.